

# Gaisa kravu pārvadājumu loģistika

Rīga, 16.01.2025

Inga Brasla





# Darbinieku apmācība

beSMART



Bīstamo izstrādājumu gaisa pārvadājumi



Litija bateriju transportēšana



Gaisa kravu pārvadājumu pamati

## Iepazīsimies:

### Inga Brasla

IATA un Latvijas CAA  
sertificēta bīstamo kravu  
instruktore

## Kontakti:

t.29143884

[www.be-smart.lv](http://www.be-smart.lv)

[training@be-smart.lv](mailto:training@be-smart.lv)

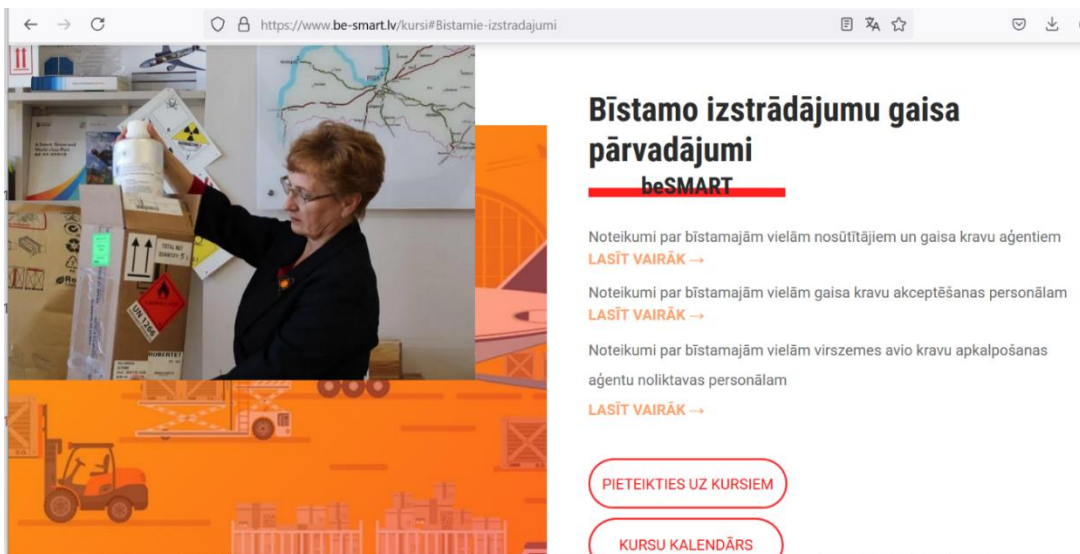

# Temati

## 1. Avio kravas, to pārvadājumu loģistika

- \* Gaisa kravu pārvadājuma organizēšanā iesaistītās organizācijas

- \* Gaisa kuģu tipi

- \* Terminoloģija, saīsinājumi

- \* Normatīvie akti, pārvadātāja maksimālās atbildības limiti

## 5. Apjoma un apmaksājamais svars, pārvadājuma cenas veidošanās

## 6. IATA prasības AWB izdošanai

## 7. Slēptās/nedeklarētās bīstamās preces – drauds aviācijas drošībai

# Starptautiskās organizācijas

- ICAO
- IATA
- CASS
- FIATA
- CAA



# ICAO: International Civil Aviation Organisation

[www.icao.int](http://www.icao.int)

- ICAO is part of the United Nations, based in Montreal.
- Its objectives are to develop the principles and techniques of international air navigation and to foster the planning and development of international air transport
- ICAO regulates air transportation throughout the world. It is responsible for the safety and security of the airways.

## Its legislation covers:

- Pilot and Crew Licensing and Training
- Aircraft safety, air navigation and air routes
- Air security
- Dangerous Goods Legislation

# IATA: Interantional Air Transport Association

[www.iata.org](http://www.iata.org)

- IATA is voluntary , non-political industry association which serves as a forum for airlines to develop common programmes for the smooth running of the international air transport system.

## The aims of IATA are:

- To promote safe, regular and economical air transport for the benefit of the peoples of the world, to foster air commerce and to study the problems connected with air transport
- To provide the means for collaboration among air transport enterprises engaged directly or indirectly in international air transport services
- To cooperate with ICAO and other international organisations

# IATA TACT Rules

IATA regularly publishes *Rules book*. It contains:

- Industry, country and carrier rules
- IATA rules on the acceptance of goods and Air Waybill completion
- Country rules, regulations and charges on import, transit and export
- Airport and storage facilities, handling equipment
- Airline, city and airport codes, AWB prefixes, etc



Valsts aģentūra  
"Civīlās aviācijas aģentūra"

### Noderīgi

- Jaunumi
- Publikācijas un pārskati
- Latvijas aviācijas vēsture

### Informācija

- Pasažieriem
- Aviācijas drošums un drošība
- Reģistri
- Normatīvie akti

### Kontakti

- Vadība
- Iestādes kontakti
- Darbinieku kontakti
- Struktūra

# CAA: Civil Aviation Authority

- CAA is governing body for air transportation in Latvia, Estonia, Lithuania, etc
- Any airline wishing to fly into or out of the country must first obtain CAA approval.
- CAA is responsible for air navigation, air traffic control and for all aspects of safety, including the carriage of dangerous goods by air.

# Gaisa kravu ekspeditors/ kravu aģents

Ekspedīcijas uzņēmumi ir starpnieki starp klientu (nosūtītājs/saņēmējs) un avioliñiju.

IATA (Starptautiskā gaisa transporta asociācija) ir izvirzījusi minimālās prasības šīm kravu aģentūrām attiecībā uz personāla apmācību, aprīkojumu, finansiālo stāvokli.

- Aģentūras, kas atbilst noteiktajiem kritērijiem, tiek sauktas par: IATA registered agents.

**IATA reģistrētās kravu aģentūras darbojas IATA avioliñiju uzdevumā un tiek uzskatītas par partneriem gaisa kravu transportēšanas procesā**

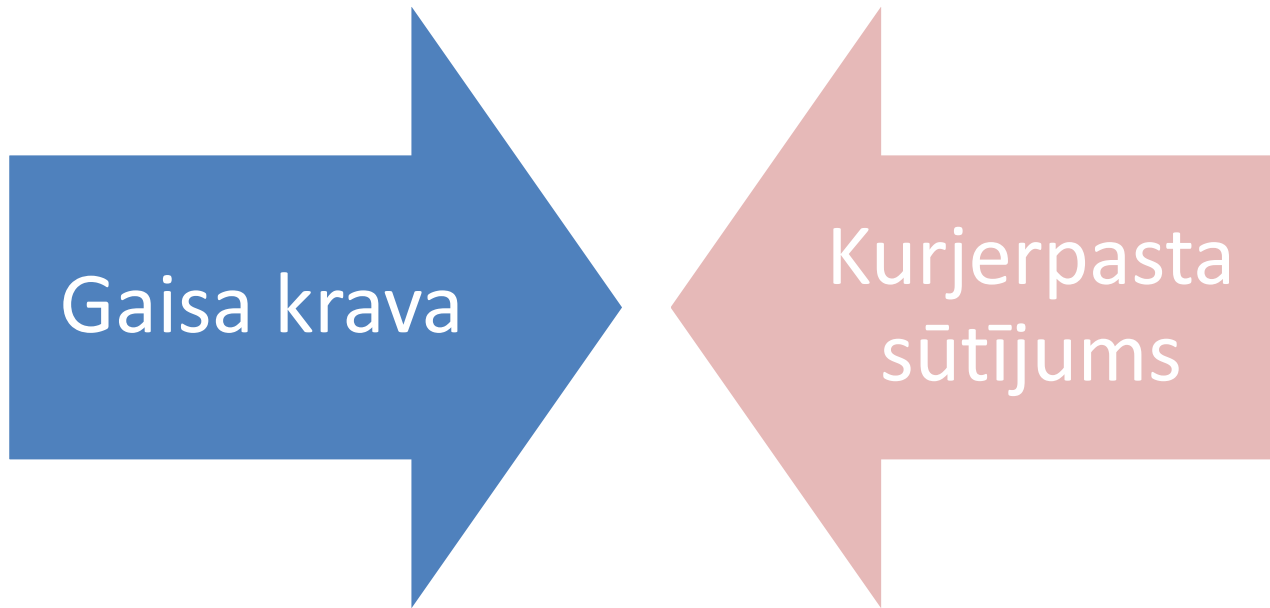

- Vai tas ir viens un tas pats?
- Kas kopīgs, kas atšķirīgs?

# Kopīgais un atšķirīgais



Gaisa krava

- Transports no lidostas līdz lidostai (t.sk.pārvadātāja atbildība un limiti)
- Atšķirīga formula apmaksājamā svara (*chargeable weight*) aprēķināšanai
- Nav svara, izmēru, preču veida ierobežojumu



Kurjerpasta sūtījums

- Transports no durvīm līdz durvīm (t.sk.pārvadātāja atbildība un limiti)
- Atšķirīga formula apmaksājamā svara (*chargeable weight*) aprēķināšanai
- Svara, izmēru, preču veida ierobežojumi

# Gaisa kravas pārvadājuma «ķēde»

(eksports)

Kravu aģents

Ģenerālais pārdošanas un servisa aģents (GSSA)

Virszemes apkalpošanas aģents (GHA)

Lidosta

Aviolīnija

# ***Kravu aģents/ ekspeditors***

## Daži piemēri LV:

- Jas Worldwide
- K&N
- ACE
- Schenker
- Beweship
- DSV
- Baltilogistika
- VIM Agency
- AXIA Logistics Latvia
- LETT2000,
- Unicore
- Quinot Logistics
- Sonora
- Helmann

## **Galvenās funkcijas (eksports):**

- Pārvadātāja izvēle un maršruta izstrāde
- Izmaksu aprēķināšana
- AWB izdošana
- Vietas rezervācija uz reisiem
- Pārvadājuma maksas iekasēšana

## Papildus pakalpojumi (pēc pieprasījuma):

- Kravu muietošana
- Kravu pakošana, marķēšana
- nogāde uz lidostu
- pakalpojumu saskaņošana ar ārzemju partneriem

# Kravu aģents/ ekspeditors

## Daži piemēri LV:

- Jas Worldwide
- K&N
- ACE
- Schenker
- Beweship
- DSV
- Baltilogistika
- VIM Agency
- AXIA Logistics Latvia
- LETT2000,
- Unicore
- Quinot Logistics
- Sonora
- Helmann

## Galvenās funkcijas (**imports**):

- pakalpojumu saskaņošana ar ārzemju partneriem
- Pārvadātāja izvēle un maršruta izstrāde
- Pārdošanas cenas aprēķināšana un saskaņošana ar partneri
- Pārvadājuma maksas iekasēšana un pārskaitīšana ārzemju partnerim

## Papildus pakalpojumi (pēc pieprasījuma):

- Kravu importa atmuitošana
- nogāde no lidostas līdz durvīm

# GSSA – General Sales and Service Agent

Nekontaktējas ar nosūtītāju

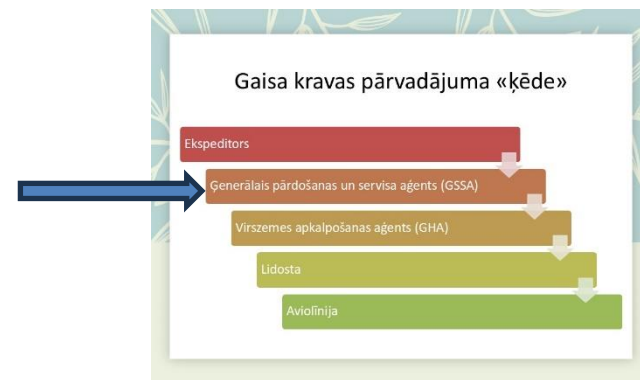

Tikai **eksporta** virziens-  
starpnieks starp ekspeditoru un virszemes  
apkalpošanu (GHA)

Daži piemēri LV:

- Airproxy: LH, OK, SK, SQ
- Skypartners: AY, QR
- airBaltic Cargo: BT
- Kales: TK, DHL Aviation
- Strike: LO

- avioliņiju cenu lapas
- Speciālās cenas (*spot rates*)
- awb numuri
- vietas rezervēšana avioliņijas sistēmā
- GHA informēšana par rezervācijām uz konkrētiem reisiem
- Atskaites avioliņijai par izmantotajiem AWB #
- problēmu risināšana tranzītā

# GHA – Ground Handling Agents

Kontakts ar visiem



## Aģenti Rīgas lidostā:

- Baltijas Kravu Centrs
- AG Handling
- Aviation cargo transit services

Katrs *GHA* noslēdzis līgumus ar konkrētām avioliņijām un apkalpo tikai tās

# GHA – Ground Handling Agents

Kontakts ar visiem



## Aģenti Rīgas lidostā:

- Baltijas Kravu Centrs
- AG Handling
- Aviation cargo transit services

\* maksas pakalpojumi

## **Eksporta** gadījumā:

- \* Kravu pieņemšana, akceptēšana, reģistrēšana
- \* Speciālo kravu atbilstības pārbaude
- \* Kravu drošības pārbaude (ar rentgenu)
  - Kravu komplektēšana konkrētam reisam
  - Kravu muitas statusa pārbaude
  - Reisa dokumentu sagatavošana:
    - Manifests
    - Info kapteinim (NOTOC)
- Sūtījumu statusa atjaunošana sistēmā

# GHA – Ground Handling Agents

Kontakts ar visiem



## Aģenti Rīgas lidostā:

- Baltijas Kravu Centrs
- AG Handling
- Aviation cargo transit services

## Importa gadījumā:

- Kravu un to dokumentu saņemšana no reisa
- Kravu šķirošana, pārbaude un reģistrēšana sistēmā
- Kravu bojājuma aktu sastādīšana (ja krava bojāta vai daļa pazudusi)
- Saņēmēju informēšana par ienākušajām kravām
- Kravu muitas statusa pārbaude
- Kravu izsniegšana saņēmējiem

# GHA – Ground Handling Agents

Kontakts ar visiem



## Aģenti Rīgas lidostā:

- Baltijas Kravu Centrs
- AG Handling
- Aviation cargo transit services

## Importa gadījumā:

- Kravu un to dokumentu saņemšana no reisa
- Kravu šķirošana, pārbaude un reģistrēšana sistēmā
- Kravu bojājuma aktu sastādīšana (ja krava bojāta vai daļa pazudusi)
- Saņēmēju informēšana par ienākušajām kravām
- Kravu muitas statusa pārbaude
- Kravu izsniegšana saņēmējiem

# GHA – Ground Handling Agents

Kontakts ar visiem



## Aģenti Rīgas lidostā:

- Baltijas Kravu Centrs
- AG Handling
- Aviation cargo transit services

Tranzīta gadījumā daļa uzdevumu gan no importa, gan eksporta

## Importa gadījumā:

- Kravu un to dokumentu saņemšana no reisa
- Kravu šķirošana, pārbaude un reģistrēšana sistēmā
- Kravu bojājuma aktu sastādīšana (ja krava bojāta vai daļa pazudusi)
- Saņēmēju informēšana par ienākušajām kravām
- Kravu muitas statusa pārbaude
- Kravu izsniegšana saņēmējiem

# Lidosta, lidostas virszemes apkalpošanas dienesti

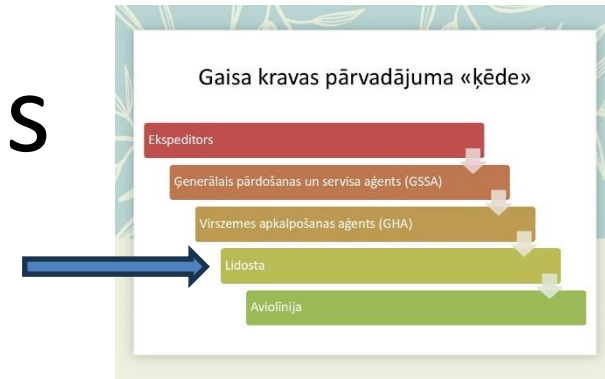

- Kravu apstrāde uz perona
- Izkraušana/iekraušana lidaparātos
- Speciālo kravu iekraušanas plānošana

Līgumi ar avioliņijām

# Pārvadātājs (aviolīnija)

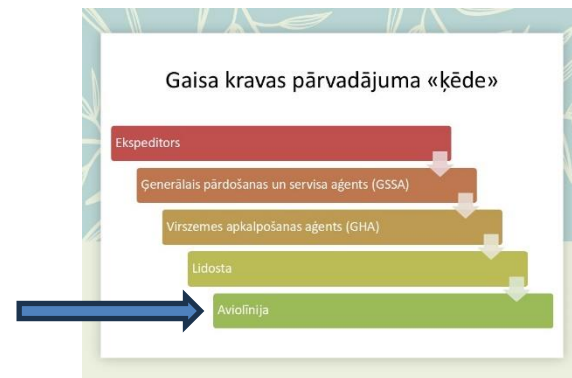

- Kravu nogāde galapunktā pa pašas izvēlētu maršrutu saprātīgos termiņos (*within reasonable dispatch*)
- Pārvadājuma līgumā atrunāts, ka drīkst izmantot arī citus transporta veidus (*visbiežāk: RFS= Road Feeder Service*)
- Visbiežāk pārvadājumu veic 1 aviolīnija; kravu nodošana citam pārvadātājam tikai saskaņā ar savstarpējiem līgumiem

# Temati

## 1. Avio kravas, to pārvadājumu loģistika

\* Gaisa kravu pārvadājuma organizēšanā iesaistītās organizācijas

\* Gaisa kuģu tipi

\* Terminoloģija, saīsinājumi

\* Normatīvie akti, pārvadātāja maksimālās atbildības limiti

5. Apjoma un apmaksājamais svars, pārvadājuma cenas veidošanās

6. IATA prasības AWB izdošanai

7. Slēptās/nedeklarētās bīstamās preces – drauds aviācijas drošībai

# Lidaparātu (AC) tipi

- Kravas lidmašīnas (All-Freight aircraft; freighter)
- pasažieru lidmašīnas :
  - platās
  - šaurās
- Citi veidi: droni, helikopteri

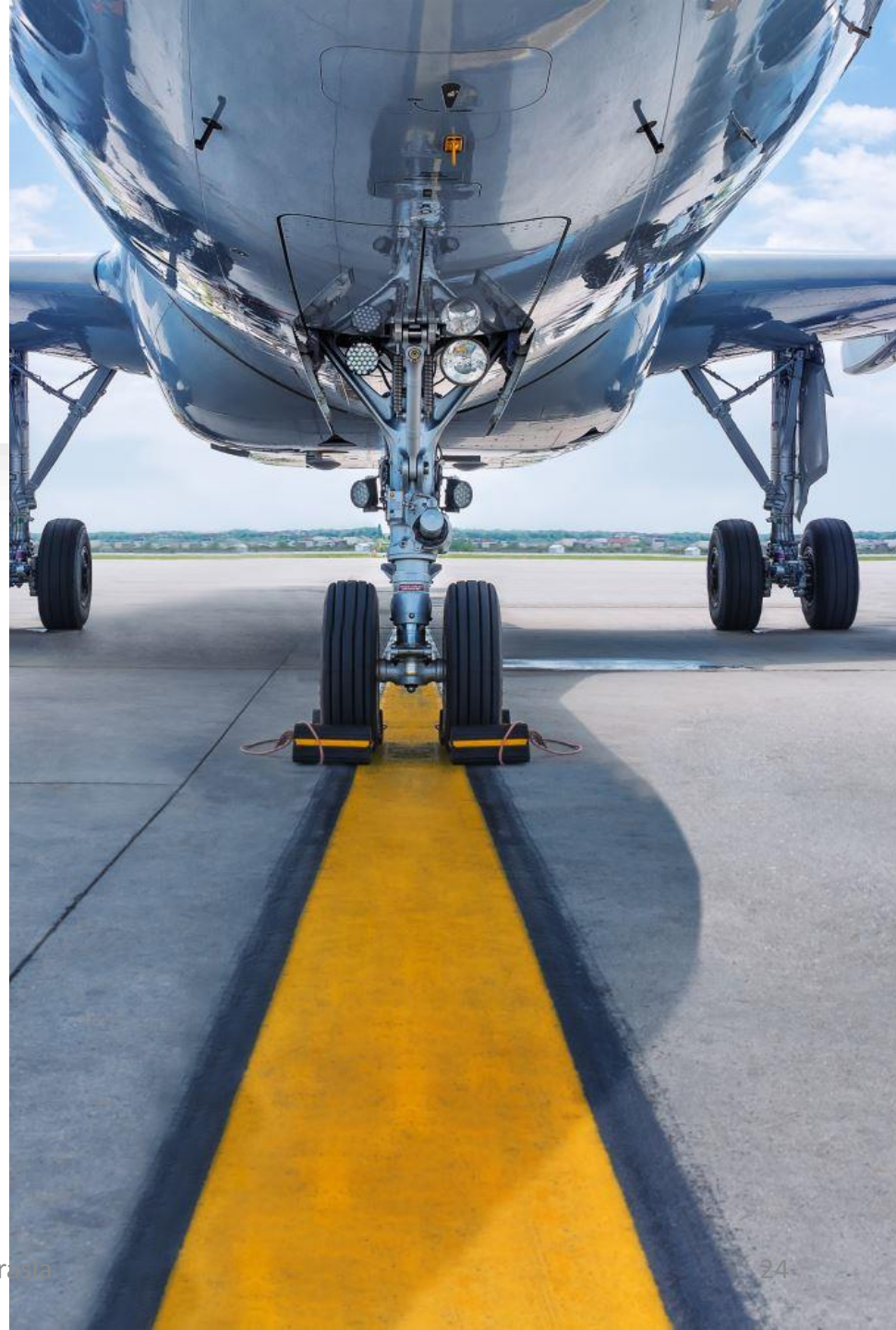

# Freighter (all cargo AC)





# Wide-body PAX AC

**Large AC with 2 passenger  
aisles**

**Fuselage diameter 5 – 6 m**

# Narrow body PAX AC



- Just 1 passenger aisle
- Fuselage diameter 3 m
- Cargo loaded without ULDs

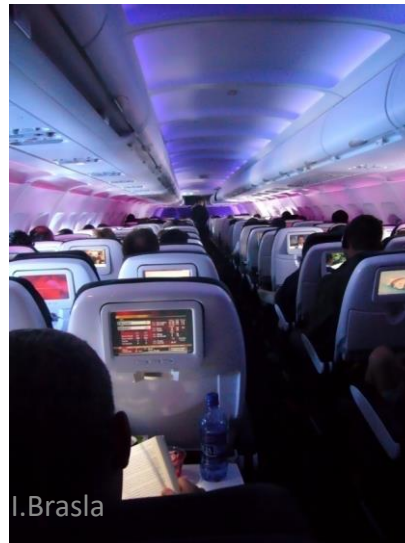

# AC types

<b>WIDE-BODIED</b>		<b>NARROW-BODIED</b>	
<b>AIRBUS:</b>	<b>A300, A310, A330 A340, A380</b>	<b>AIRBUS:</b>	<b>A319, A320, A321</b>
<b>BOEING</b>	<b>747, 767, 777, 787</b>	<b>BOEING:</b>	<b>757, 737</b>
<b>McDonnell Douglas:</b>	<b>DC10, MD11</b>	<b>McDonnell Douglas:</b>	<b>DC9, MD9, MD80</b>
		<b>Fokker</b>	<b>F27, F28, F50, F100</b>
		<b>ATR</b>	<b>ATR72</b>

# Loading charts

## /Boeing 737-300/

height

<b>13</b>	429	358	307	269	241	213	188	165	
<b>25</b>	389	333	295	267	241	213	188	165	
<b>30</b>	376	328	295	267	241	213	188	165	
<b>36</b>	368	323	292	267	241	213	188	165	147
<b>41</b>	361	320	292	267	241	213	188	165	147
<b>46</b>	356	318	292	267	241	213	188	165	147
<b>51</b>	353	318	292	267	241	213	188	165	147
<b>56</b>	348	315	292	267	241	213	188	165	147
<b>61</b>	345	315	292	267	241	213	188	165	147
<b>66</b>	345	315	292	267	241	213	188	165	147
<b>71</b>	343	312	292	267	241	213	188	165	147
<b>76</b>	340	312	292	267	241	213	188	165	147
<b>81</b>	340	312	292	267	241	213	188	165	147
<b>86</b>	340	312	292	267	241	213	188	165	147
	<b>13</b>	<b>25</b>	<b>38</b>	<b>51</b>	<b>64</b>	<b>76</b>	<b>89</b>	<b>102</b>	<b>114</b>
	<b>width</b>								

??

- 1) 120 x 80 x 65 cm
- 2) 330 x 25 x 40 cm

I. Brasa

## Airbus A220-300

Width (cm)	Maximum package length									
	Height (cm)									
	0-30	30-51	51-58	58-64	64-69	69-74	74-76	76-79	79-81	81-84
0-8	584	541	462	411	363	318	295	274	249	221
8-15	569	483	419	378	338	297	277	257	234	211
15-23	505	437	386	351	315	279	259	244	224	201
23-30	457	401	356	325	295	264	246	231	211	191
30-38	417	371	333	305	277	249	234	221	203	183
38-46	384	345	312	287	264	236	224	211	193	175
46-53	356	323	295	272	251	226	213	201	185	168
53-61	333	302	279	259	239	216	203	193	179	160
61-69	312	287	264	249	229	208	196	185	172	155
69-76	297	272	254	236	218	201	188	178	165	150
76-84	282	262	244	229	211	193	180	173	157	142
84-91	269	249	234	218	204	185	175	165	152	137
91-99	257	239	223	211	196	178	168	157	145	130
99-107	246	229	216	201	185	168	157	147	135	119
107-114	216	196	180	165	150	132	119	112	97	84

**Question:** *Is a piece with dims 140 x 90 x 85 cm loadable on both aircraft?*

# Turkish airlines B777

## Aircraft Features

Net Cargo Payload:	20.000 kg / 80 m <sup>3</sup>	<b>Height Limits</b> in Aircraft:	<b>163 cm</b> Max
Main Deck Door Dimensions:	-	Maximum Cargo Capacity (Main Deck):	-
Lower Deck Front Door Dimensions:	269 x 170 cm	Maximum Cargo Capacity (Lower Deck Front):	40.823 kg / 72 m <sup>3</sup>
Lower Deck After Door Dimensions:	269 x 170 cm	Maximum Cargo Capacity (Lower Deck After):	31.751 kg / 54 m <sup>3</sup>
Bulk Cargo Compartment Door Dimensions:	91 x 114 cm	Maximum Capacity (Bulk Cargo Compartment):	4.082 kg x 17 m <sup>3</sup>

# ULD (*unit load device* = air cargo containers)

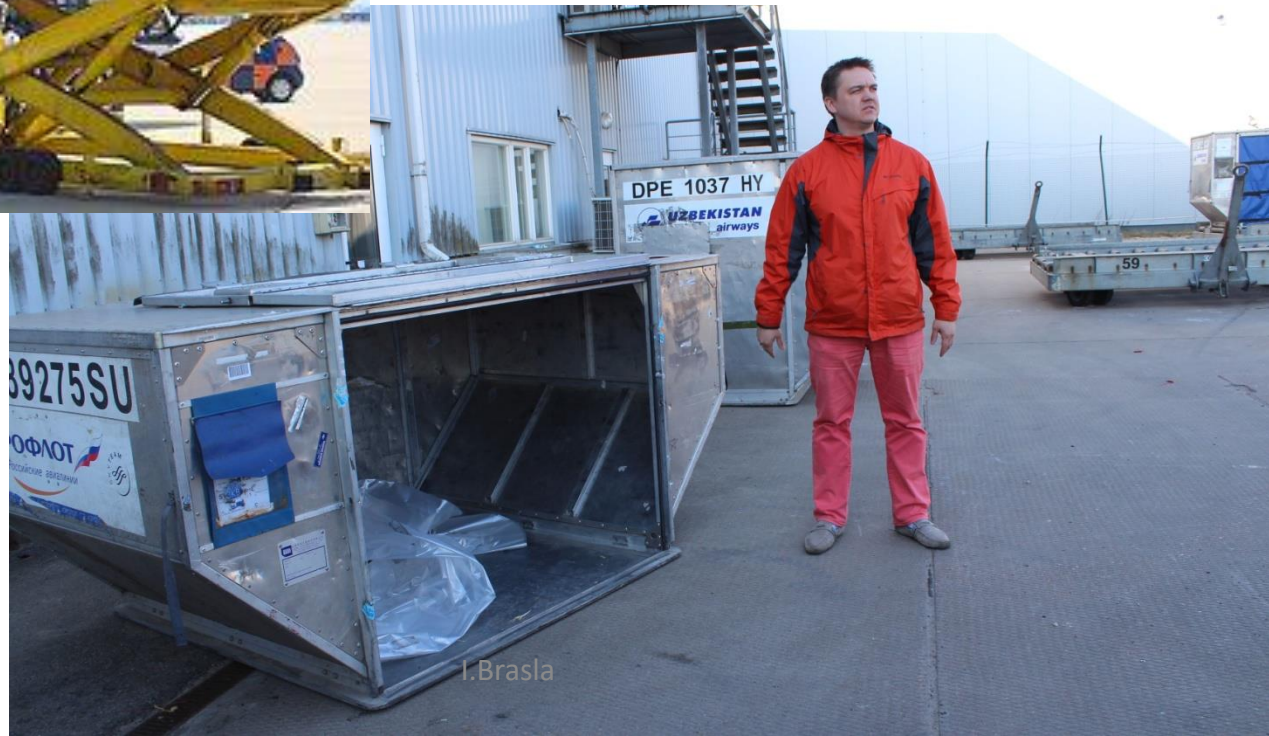

I.Brasla

### LD-1

IATA ULD Code: AKC Contoured Container  
Also known as: AVC, AVD, AVK, AVJ  
Forkable: AVY  
Classification: LD-1  
Rate Class: Type 8  
Suitable for: B747, B767, B777, MD-11  
Internal volume: 4.8 cu. m (169.5 cu. ft)  
Maximum gross weight: 1588 kg (3501 lb)



### LD-2

IATA ULD Code: DPE Contoured Container  
Also known as: APA, DPA  
Forkable: DPN  
Classification: LD-2  
Rate Class: Type 8D  
Suitable for: B767  
Internal volume: 3.4 cu.m (120 cu. ft)  
Maximum gross weight: 1225 kg (2700 lb)

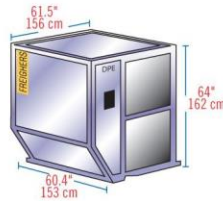

### LD-3

IATA ULD Code: AKE Contoured Container  
Also known as: AKE, AVA, AVB, AVC, AVK, DVA, DVE, DVP, XKS, XKG  
Forkable: AKN, AVN, DKN, DVN, XKN  
Classification: LD-3  
Rate Class: Type 8  
Suitable for: A300, A310, A330, A340, B747, B767, B777, DC-10, MD-11, L1011  
Internal volume: 4.3 cu.m (152 cu. ft)  
Maximum gross weight: 1588 kg (3500 lb)

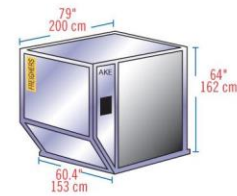

### Insulated LD-3

IATA ULD Code: RKN  
Classification: LD-3  
Rate Class: Type 8  
Suitable for: A300, A310, A330, A340, B747, B767, B777, DC-10, MD11, L1011  
Internal volume: 3.0 cu.m (109 cu. ft)  
Maximum gross weight: 1588 kg (3500 lb)  
Temperature Control Range: -20C to +20C



### LD-4

IATA ULD Code: ALP Rectangular Container  
Also known as: ALD, AWD, AWZ, DLP  
Forkable: ALB, ALC, AWB, AWC  
Classification: LD-4  
Rate Class: Type 8  
Suitable for: B767, B777  
Internal volume: 5.7cu. m (201 cu. ft)  
Maximum gross weight: 2449 kg (5399 lb)

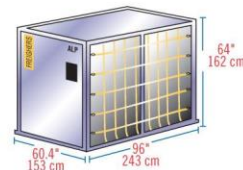

### LD-6

IATA ULD Code: ALF Contoured Container  
Also known as: AWD, AWF  
Forkable: AWC  
Classification: LD-6  
Rate Class: Type 6W  
Suitable for: A300, A310, A330, A340, B747, B777, DC-10, MD-11, L1011  
Internal volume: 8.9 cu. m (314 cu. ft)  
Maximum gross weight: 3175 kg (7000 lb)

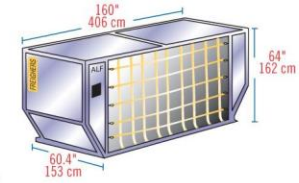

### LD-7

IATA ULD Code: XAW P1P Pallet with fixed angle wings and net  
Classification: LD-7  
Rate Class: Type 5  
Suitable for: Wide body: All aircraft  
Maximum volume with overhang: 14.0 cu. m (494 cu. ft)  
Maximum gross weight: 5000 kg (11023 lb)

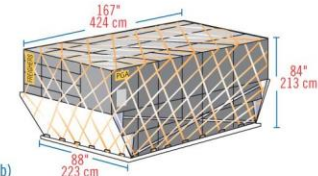

### LD-8

IATA ULD Code: DQP  
Also known as: ALE, ALN, DLE, DLF, DQP, MQP  
Classification: LD-8  
Rate Class: Type 6A  
Suitable for: B767  
Internal volume: 6.85 cu. m (242 cu. ft)  
Maximum gross weight: 2450 kg (5401 lb)

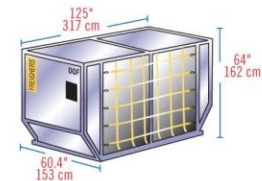

### LD-9

IATA ULD Code: AAP Enclosed Pallet on P1P base  
Also known as: AA2, XAG, XAV  
Classification: LD-9  
Rate Class: Type 5  
Suitable for: A300, A310, A330, A340, B747, B767, DC-10, MD-11, L1011  
Internal volume: 9.1 cu. m (321 cu. ft)  
Maximum gross weight: 4624 kg (10194 lb) lower deck  
6000 kg (13227 lb) main deck

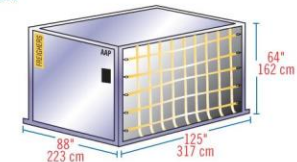

### LD-11

IATA ULD Code: ALP Rectangular Container  
Also known as: ALD, AW2, AWB, AWD, AWZ, DLP, DWB, MWB  
Refrigerated version: RWB, RWD, RWZ  
Classification: LD-11  
Rate Class: Type 6  
Suitable for: A300, A310, A330, A340, B747, B777, DC-10, MD-11, L1011  
Internal volume: 7.2 cu. m (253 cu. ft)  
Maximum gross weight: 3176 kg (7002 lb)

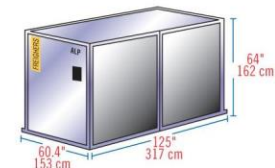

### A-2

IATA ULD Code: DAA  
Classification: A-2  
Suitable for: B747, B747F, DC8, DC10, A300/F  
Internal volume: 12.6 cu. m (444 cu. ft)  
Maximum gross weight: 6033 kg (13300 lb)





# Coding

- FLY
- EVE
- TOY
- DAY
- FAT
- BOY
- NYC
- ARM
- LEG
- RIX
- TLL

# Lidostu/pilsētu kodi

- FLY
- EVE
- TOY
- DAY
- FAT
- BOY
- NYC
- ARM
- LEG
- RIX
- TLL
- Finley, Australia
- Evenes, Norway
- Toyama, Japan
- Dayton, Ohio, US
- Fresno, California, US
- Bobo Dioulass, Burkina Faso
- New York City
- Armidale, Australia
- Aleg, Mauritania
- Riga, Latvia
- Tallinn, Estonia



# Avioliņiju kodi

- LH
  - BT
  - OK
  - AY
  - TK
  - LO
  - SU
  - HY
  - AA
  - CO
  - SK
  - CA
  - CI
  - 6Y
  - LUFTHANSA
  - airBaltic
  - Czech Airlines
  - Finnair
  - Turkish Airlines
  - LOT Polish
  - Aeroflot Russian Airlines
  - Uzbekistan Airways
  - American Airlines
  - Continental Airlines
  - Scandinavian Airlines System (SAS)
  - Air China
  - China Airlines
  - SmartLYNX
- 020-  
657-  
064-  
105-  
235-  
080-  
555-  
250-  
001-  
005-  
117-  
999-  
297-

# Lidojumu saraksti

## Lufthansa Timetable

› SAS Cargo Timetable

› **Lufthansa Timetable**

› Czech Airlines Timetable

› Singapore Airlines Timetable

› Coyne Airways Timetable

### Tallinn, Estonia

Origin	Destination	LAT	STD	STA	Flight nr	A/C Type	Weekdays
TLL	FRA	16:05	18:05	19:50	LH883	A319/A320	1234567
TLL	HEL	16:00	18:00	10:00+1	LH6215s	RFS	1234
TLL	HEL	16:00	18:00	10:00+1	LH7418s	RFS	5

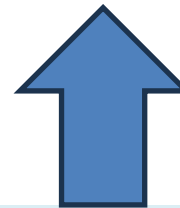

LAT: Latest Acceptance Time

STD: Said to Depart

STA: Said to Arrive

# Ready for Carriage

IATA resolution 833 states that IATA cargo agent must present shipments to the airline „Ready for Carriage” (**TACT 2.3.2**)

## The air waybill:

- This must be issued in accordance with Section 6 of TACT Rules. Weights, dimensions and the nature of the goods must always be checked.

## Documentation:

- All necessary documents according to the requirements of the country of destination must have been completed and checked for each consignment. The documents must accompany the airwaybill. TACT Rules Section 7 gives up-to-date information by country.

# Ready for Carriage (2)

## Marking of Packages

- All packages must show the same consignee name, city and street address as that on the air waybill.

## Packing

- The packages must be able to withstand normal transport conditions

## Labelling of packages

- Labels must be fully visible and all former labels and markings removed. A cargo label must be attached to each package. Standard labels for special cargoes must be affixed to the package to which they relate (eg Dangerous goods, Live animals, etc).

# Uzlīmju piemēri





Shipping paper description for 1L of Benzene, 3, II, ltd qty, erboard box X 1L



## Ready for Carriage (3)

- The Shipper's Declaration for Dangerous goods must be provided by the shipper
- The Shipper's Certification for Live Animals is required duly signed and completed



# Temati

## 1. Avio kravas, to pārvadājumu loģistika

\* Gaisa kravu pārvadājuma organizēšanā iesaistītās organizācijas

\* Gaisa kuģu tipi

\* Terminoloģija, saīsinājumi

\* Normatīvie akti, pārvadātāja maksimālās atbildības limiti

5. Apjoma un apmaksājamais svars, pārvadājuma cenas veidošanās

6. IATA prasības AWB izdošanai

7. Slēptās/nedeklarētās bīstamās preces – drauds aviācijas drošībai

# PAR DAŽU STARPTAUTISKĀ GAISA TRANSPORTA NOTEIKUMU UNIFIKĀCIJU jeb Varšavas konvencija (1929)

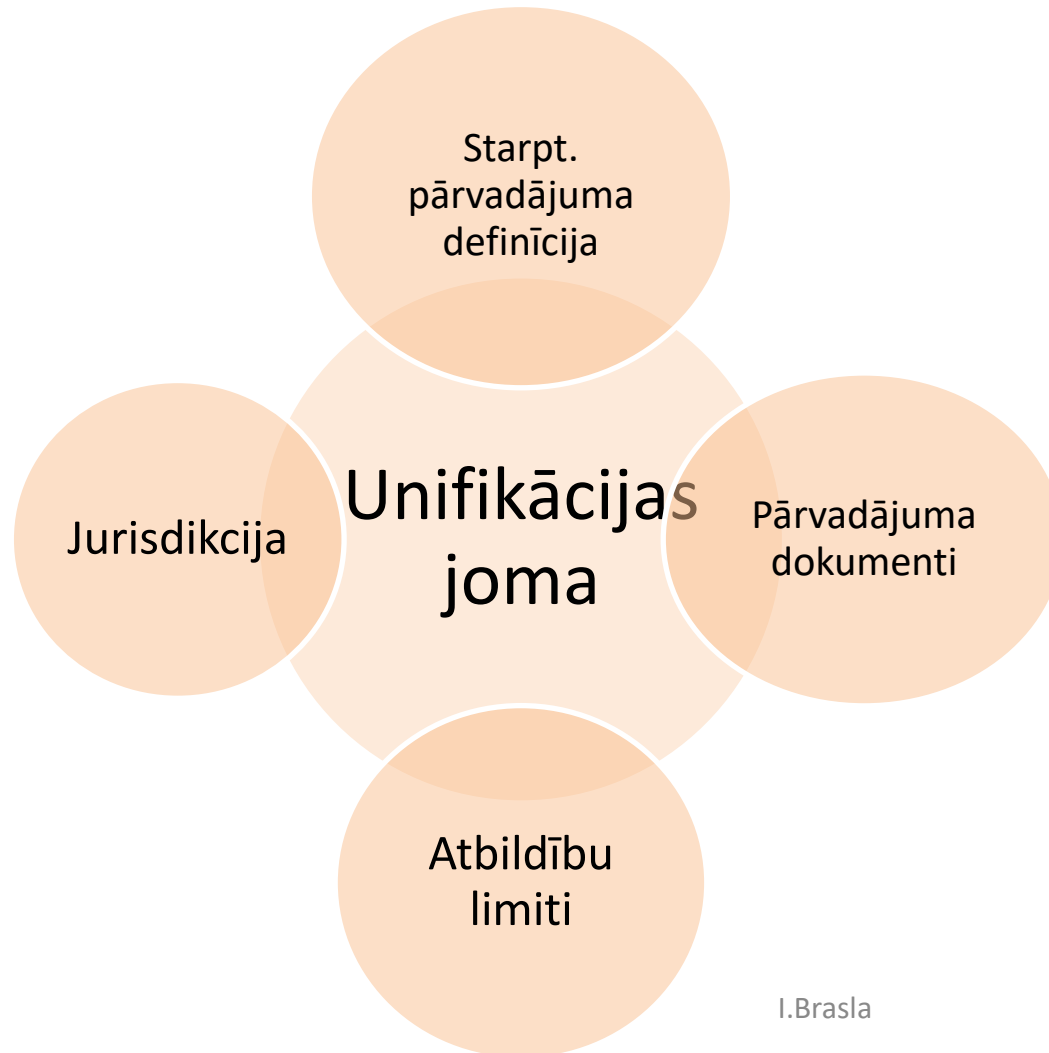

# Pārvadājuma dokumenti

## Pasažieri un bagāža

- ✈ Attiecībā uz pasažieru pārvadāšanu tiek izsniegts individuāls vai kolektīvs pārvadājuma dokuments, kurā ir ietverts:
  - sākumpunkta un galapunkta vietu norādījums;
  - ja apstāšanās vietas ir citas valsts teritorijā, norādījums par vismaz vienu šādu apstāšanās vietu.
- ✈ Pārvadātājs izsniedz pasažierim bagāžas identifikācijas zīmi katrai reģistrētās bagāžas vienībai
- ✈ Pasažierim izdod rakstisku paziņojumu par to, ka tur, kur šī Konvencija tiek piemērota, tā regulē un var ierobežot pārvadātāju atbildību attiecībā uz nāvi vai veselības bojājumiem un bagāžas iznīcināšanu, nozaudēšanu vai bojāšanu, un aizkavēšanos.

# Pārvadājuma dokumenti

## Krava

Attiecībā uz kravas pārvadājumu tiek izsniegta gaisa kravas pavadzīme

## **Gaisa kravas pavadzīmes vai kravas kvīts saturs:**

- sākumpunkta un galapunkta vietas
- kravas raksturu
- eksemplāru skaits, paraksti
- nosūtītāja un saņēmēja tiesību īstenošana
- atbildība par dokumentācijas detaļām
- dokumentācijas neapgāžamā vērtība
- nosūtītāja un saņēmēja tiesību īstenošana

# Atbildību limiti

- Pārvadātāja maksimālā atbildība:



Mūsdienās  
vairs nav  
spēkā

- 125,000 Francs par personas ievainojumiem
- 250 Francs/kg par reģistrēto bagāžu un kravu
- 5,000 Francs par ceļotāja rokas bagāžu
- Franka kurss: 65 mg zelta  
(65 milligrams gold of millesimal fineness 900)

Laika gaitā konvencija tika papildināta un labota ar vairāku protokolu palīdzību, kas apgrūtināja konfliktu izskatīšanu

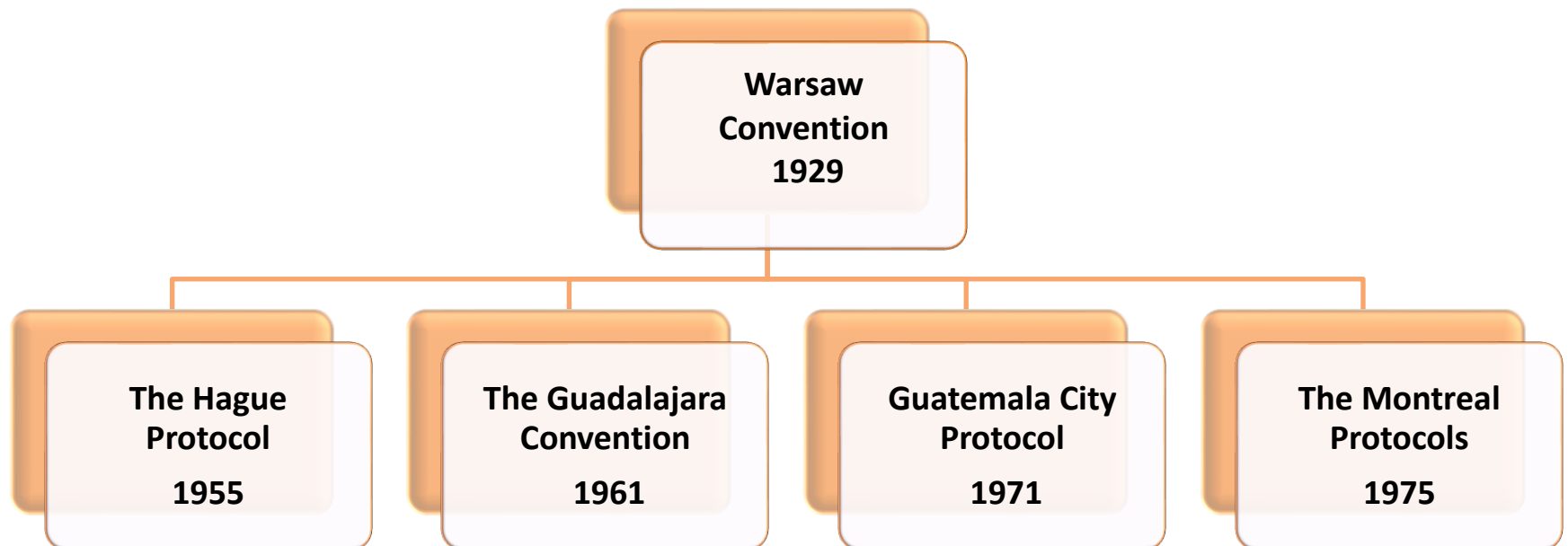

# Monreālas konvencija (1999)

<http://likumi.lv/doc.php?id=208062>

- Parakstīja 1999.g. ICAO dalībvalstis
- Izmainīja daudzus Varšavas konvencijas punktus par atbildībām, palielinot kompensācijas avio katastrofu upuriem
- Aizsargā pasažierus, ieviešot 2-pakāpju atbildības sistēmu un samazinot pierādījumu vākšanas periodu, attiecīgi saīsinot tiesāšanās procesus
- Galvenā uzmanība kompensācijām par pasažieru nāves gadījumiem cietušo ģimenēm

# Monreālas Konvencija (1999)

Sākotnējie limiti,  
kas vairākkārt  
pārskatīti



100 000 SDR/ PAX



1000 SDR/PAX



17 SDR/kg

Carrier's max liability limits/ Monreal Convention 1999

# Pārvadātāja maksimālās atbildības limiti

---

Konvencijas 24.pants paredz, ka katrus 5 gadus ICAO drīkst pārskatīt limitus, balstoties uz inflācijas rādītājiem.

**No 1999.g. 17 SDR/kg**

**No 2009.g. : 19 SDR/kg**

**No 2019.g. : 22 SDR/kg**

**No 2025.g. : 26 SDR/kg**



## Currency Weights in the SDR (and SDR Interest Rate) Basket

With effect from August 1, 2022, the IMF has determined that the five currencies that meet the selection criteria for inclusion in the SDR valuation basket will be assigned the following weights based on their roles in international trade and finance:

U.S. dollar :	43.38 %
Euro :	29.31 %
Chinese renminbi	12.28 %
Japanese yen:	7.59 %
Pound sterling:	7.44 %

# Monreālas Konvencija (1999)

Spēkā no 2025.g.



**151 880 SDR/ PAX**



**1519 SDR/baggage  
6303 SDR/ delay**



**26 SDR/kg,  
incl.delay**

**Carrier's max liability limits/ Monreal Convention/ 2025**

# Monreālas Konvencija (1999)

Spēkā no 2025.g.



151 880 SDR/  
PAX



1519

SDR/baggage  
6303 SDR/  
delay



26 SDR/kg,  
incl.delay

Carrier's max liability limits/ Monreal Convention/ 2025

Respektēt pretenziju  
iesniegšanas termiņus (skat.  
Condition of Contract)

Viss par SDR, t.sk.vērtība pret citām valūtām pa dienām-  
Starptautiskā valūtas fonda mājas lapā: [www.imf.org](http://www.imf.org)

<https://www.imf.org/en/About/Factsheets/Sheets/2023/special-drawing-rights-sdr>

## SPECIAL DRAWING RIGHTS (SDR)

ENGLISH ▾



### What is the SDR?

The SDR is an international reserve asset. The SDR is not a currency, but its value is based on a basket of five currencies –the US dollar, the euro, the Chinese renminbi, the Japanese yen, and the British pound sterling.

[LEARN MORE](#)

[Q&A ON SDRS](#)

[ONLINE COURSE ON SDRS](#)

# Claims

10. Receipt by the person entitled to delivery of the cargo without complaint shall be prima facie evidence that the cargo has been delivered in good condition and in accordance with the contract of carriage.

Have to hand in all documents related to carriage of particular goods

Note the time limits!

(see Conditions of Contract)

When damage is hidden, that means it isn't noticed until after delivery, and it isn't notated on the POD. Concealed damaged claims are tricky because they're harder to prove.

# Temati

1. Gaisa kravu pārvadājuma organizēšanā iesaistītās organizācijas
2. Gaisa kuģu tipi
3. Terminoloģija, saīsinājumi
4. Normatīvie akti, pārvadātāja maksimālās atbildības limiti
5. Tilpuma un apmaksājamais svars, pārvadājuma cenas veidošanās
6. Gaisa kravas pavadzīme
7. Speciālo kravu pārvadājumu īpatnības

# Gaisa kravas tilpuma (apjoma) aprēķini

Visos transporta veidos pārvadājuma izmaksas iespaido kravas svara un apjoma parametri, attiecīgi, lielākais no tiem būs noteicošais.



**The IATA / Airline Cubic Allowance Factor for Air Freight Shipments is  
1 Kilo = 6,000 Cubic Centimetres.**

# Fakstiskais svars = brutto svars

*(actual weight = gross weight)*

- Fakstiskais brutto svars = visa sūtījuma svars, fiksēts uz svariem (ieskaitot iepakojamos materiālus)



brutto svars

# Tilpuma svars

*(Volume weight)*

Tilpuma svars ir visu kravas vietu  
**svars attiecībā pret to izmēru**

*Formula (gaisa krava):*

$$\frac{\text{Garums} \times \text{Platums} \times \text{Augstums (cm)}}{6000}$$

$$1 \text{ m}^3 = 166.6 \text{ kg}$$

**!** Dalīt ar 5000  
kurjerpastu sūtījumiem

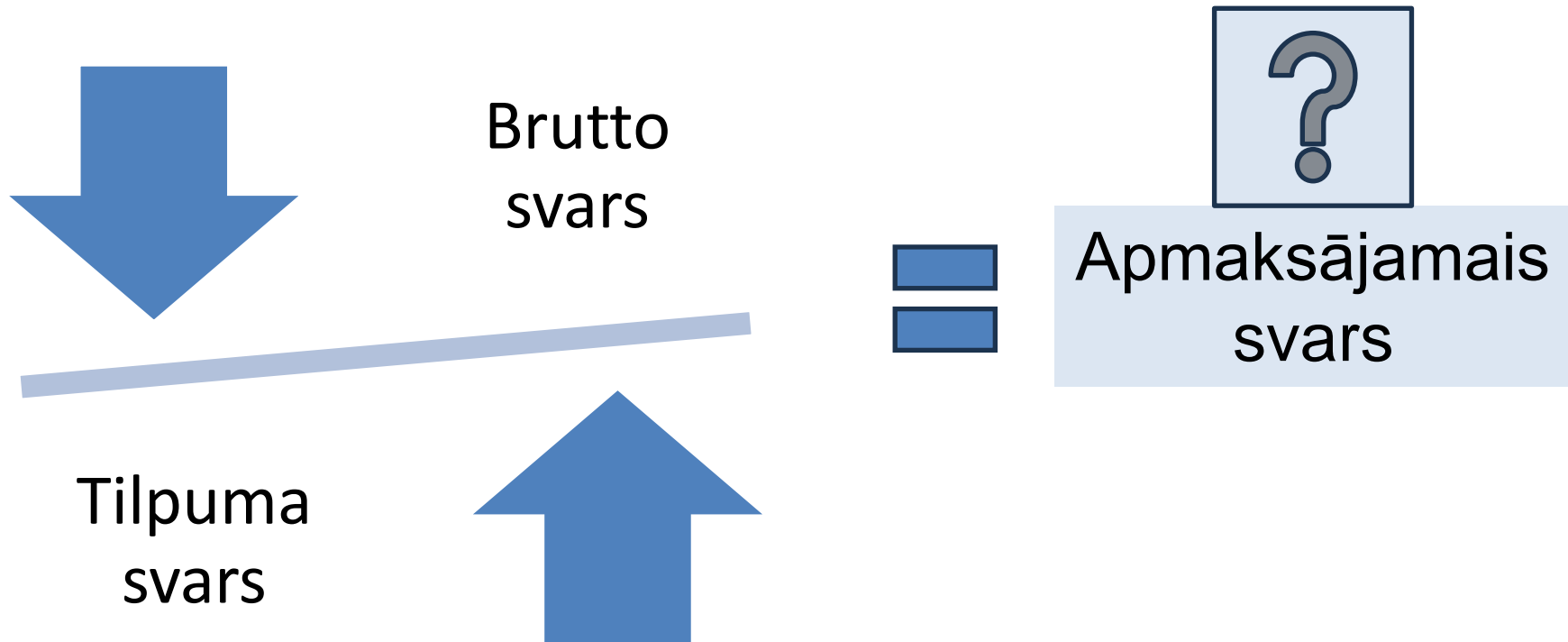

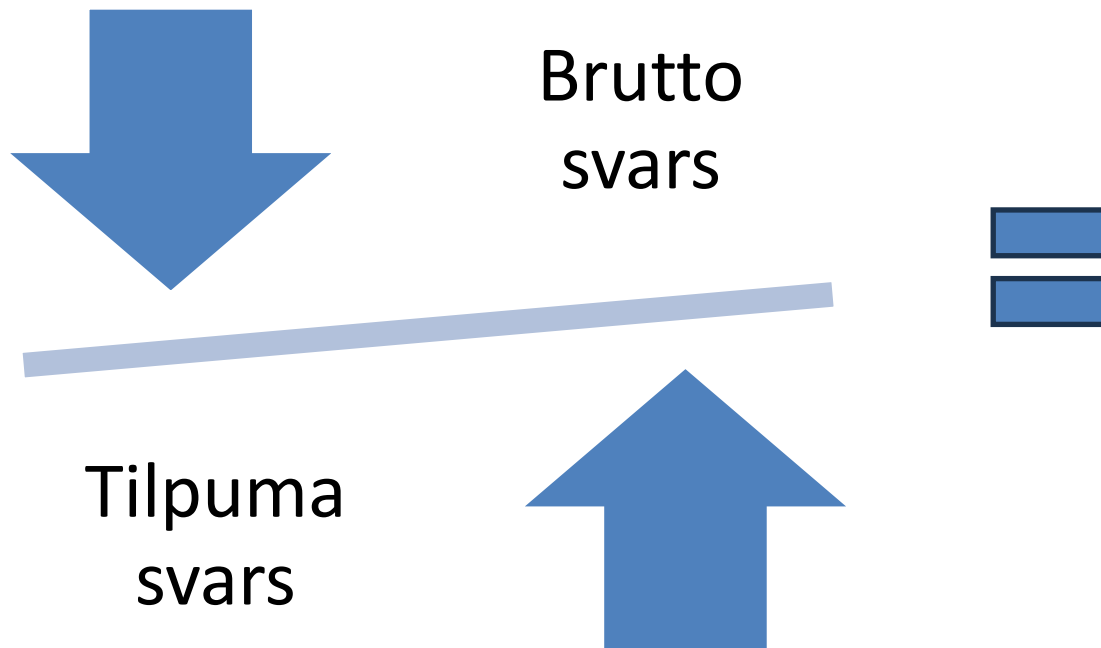

Apmaksājamais  
svars  
=  
Lielākais no  
abiem

# Aprēķināt apmaksājamo svaru (A)!



**Brutto svars 47kg**

- Pierakstīt izmērus pareizā secībā: . . . . .

**Apmaksājamais svars ir:** . . . . .

Svaru jānoapaļo līdz tuvākajam 0.5kg

# Atbilde:

Brutto svars 47kg



- Pierakstīt izmērus pareizā secībā: **120 x 45 x 78 cm** . . .

Apmaksājamā svara aprēķins:  $\frac{120 \times 45 \times 78}{6000} = \frac{421200}{6000} = 70.2 \text{ kg}$

**Pēc noapaļošanas: 70 kg**

# Aprēķināt apmaksājamo svaru (B)!

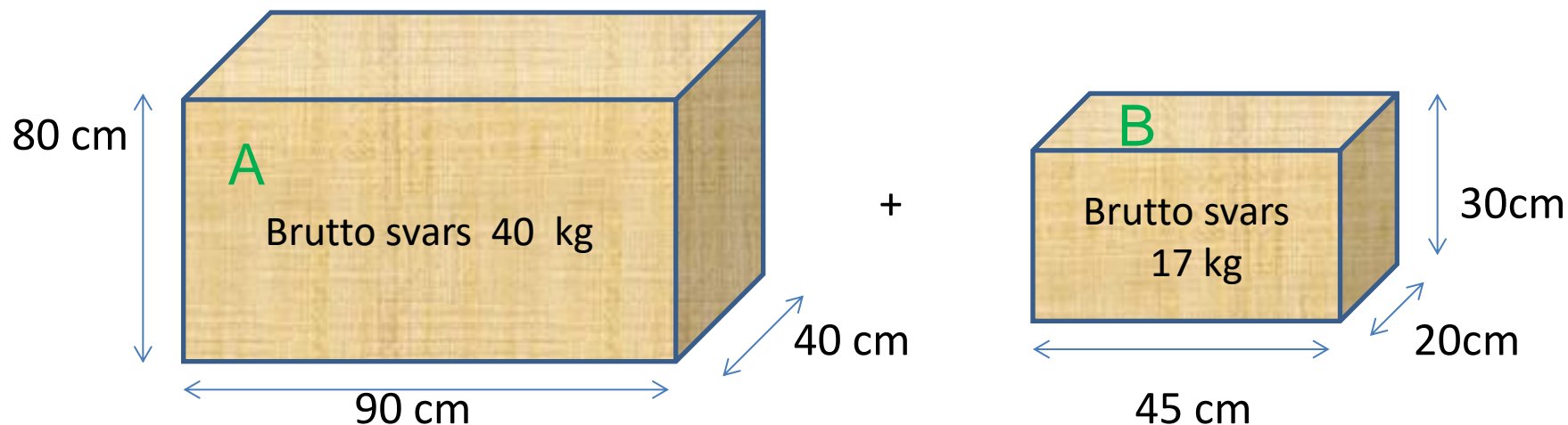

1) Pierakstīt izmērus pareizajā secībā!

2) Aprēķināt tilpuma svaru!

3) Noteikt apmaksājamo svaru!

# Atbilde (B)

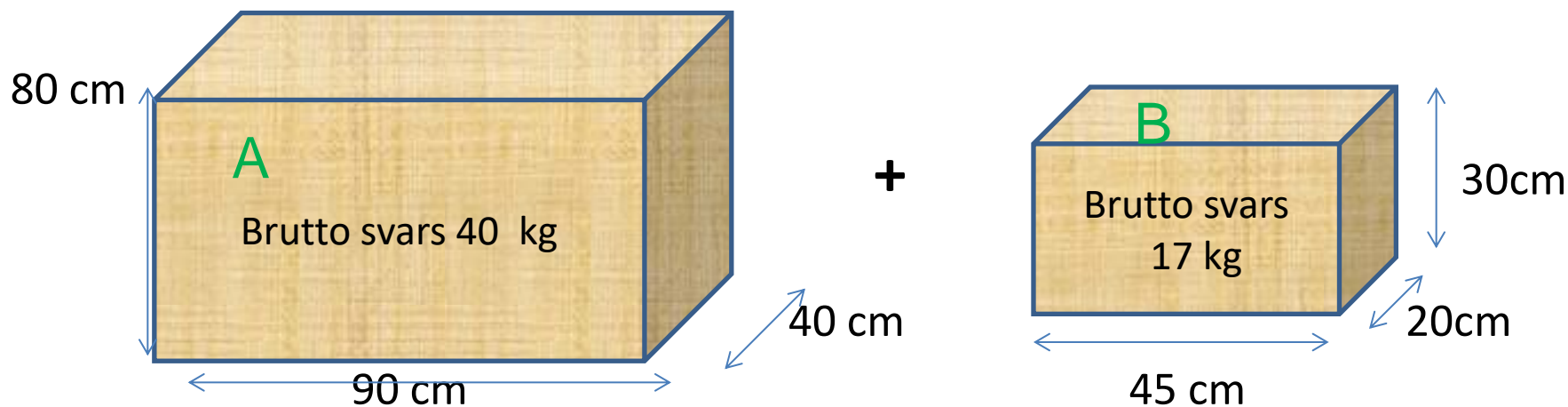

1) Izmēru pieraksts: *A) 90 x 40 x 80 b) 45 x 20 x 30*

2) *Kopējais brutto svars: 40+17=57 kg*

3) *tilpuma svara aprēķins:  $\frac{(90 \times 40 \times 80) + (45 \times 20 \times 30)}{6000} = \frac{288000 + 27000}{6000} = \frac{315000}{6000} = 52.5 \text{ kg}$*

4) *Apmaksājamais svars: 57 kg*

# Air Cargo Rating

IATA airlines base their rates on TACT  
rates/charges

**Minimum  
charges  
(M)**

**General  
Cargo  
Rates  
(N, Q)**

**Class  
Rates  
(S)**

# Air Cargo Rating (2)

There are following **rates codes**:

**M** = Minimum charges

**N** = Normal rate (under 45 kgs)

**Q** = Quantity rates (+45, +100, +300, 500 kgs)

**S** = Surcharges

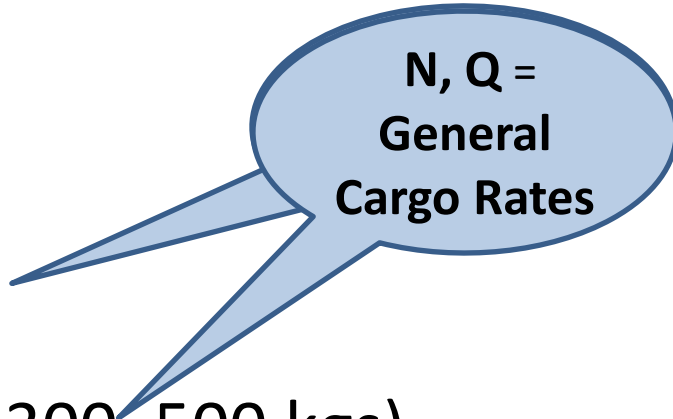

**N, Q =  
General  
Cargo Rates**

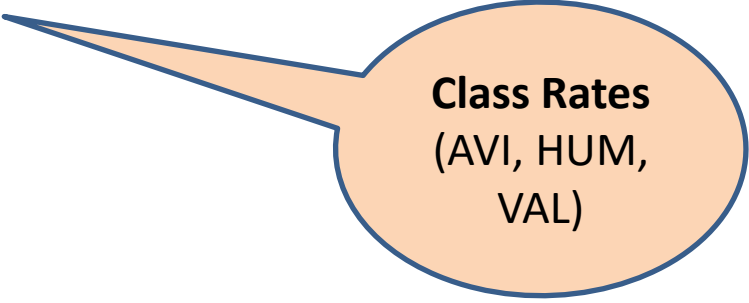

**Class Rates  
(AVI, HUM,  
VAL)**

# Freight Calculation

Rates applied  
to chargeable  
weight

Destination /carrier	M	N	Q45	Q100	Q500	MYC/kg	SCC/kg	ADC/shpt
JNB/ LH	70	3,50	3,05	2,55	2,35	1,25	0,20	14,23



# Freight Calculation

Rates applied  
to chargeable  
weight

Destination /carrier	M	N	Q45	Q100	Q500	MYC/kg	SCC/kg	ADC/shpt
JNB/ LH	70	3,50	3,05	2,55	2,35	1,25	0,20	14,23

How many kgs do we need for our minimum to be applied? -  
**divide the Minimum by the N rate:**  $70 : 3.50 = 20$  kg

1 – 20 kg = 70 EUR/Consignement

Above 20 kg respective per/kg rate to be applied

## Freight Calculation (2)

Destination /carrier	M	N	Q45	Q100	Q500	MYC/kg	SCC/kg	ADC/shpt
LON/ AY	50	4,00	3,55	2,55	2,35	1,25	0,20	14,23

How many kgs do we need for our minimum to be applied? -  
divide the Minimum by the N rate:  $50 : 4.00 = 12.50$  kg

$1 - 12.50$  kg = 50 EUR/Consignement

Above 12.50 kg respective per/kg rate to be applied

# Temati

1. Gaisa kravu pārvadājuma organizēšanā iesaistītās organizācijas
2. Gaisa kuģu tipi
3. Terminoloģija, saīsinājumi
4. Normatīvie akti, pārvadātāja maksimālās atbildības limiti
5. Tilpuma un apmaksājamais svars, pārvadājuma cenas veidošanās
6. Gaisa kravas pavadzīme (AWB)
7. Bīstamās kravas

# Airway Bill (AWB)

## **Airway Bill:**

the most important document issued by a carrier either directly or through its authorised agent. It is a non-negotiable transport document. It covers transport of cargo from airport to airport.

By accepting a shipment an IATA cargo agent is acting on behalf of the carrier whose air waybill is issued.

# Main AWB functions

- Contract of Carriage
- Evidence of Receipt of Goods
- Freight Bill
- Guide to carrier's staff in handling, dispatching and delivering the consignment

# AWB set

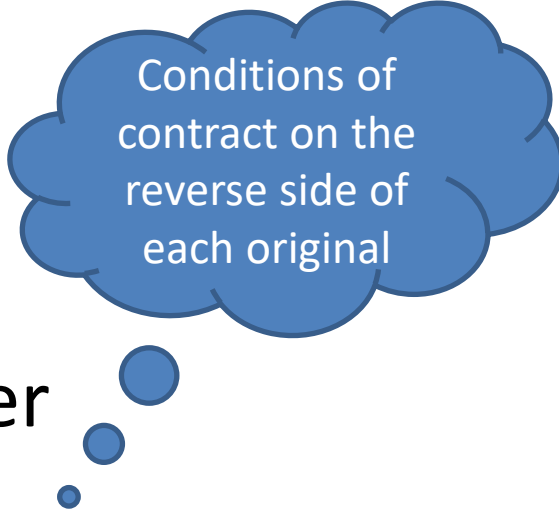

Conditions of contract on the reverse side of each original

## 3 originals:

- Original 1 (**green**): for issuing carrier for accounts purposes
- Original 3 (**blue**): for shipper
  - proof of receipt of the goods for shipment;
  - documentary evidence of carrier's and shipper's signature to the contract of carriage
- Original 2 (**pink**): for consignee to accompany consignment to final destination and to be tendered to consignee upon delivery

# AWB set

/continued/

---

Other parts – copies of the originals: .....

---



Why so many copies?

Copy 4: delivery receipt

---

Copy 5 – for destination

---

Copy 6 – for 3rd carrier

---

Copy 7 – for 2nd carrier

---

Copy 8: **for agent**

---

Copy 9-12 – copies

---

Only Copy 8 can be removed by the agent

# Responsibility of Completion

- In accordance with the Warsaw Convention and the carrier's conditions of Contract the Shipper shall prepare the AWB.
- The shipper is responsible for the correctness of the particulars and statements relating to the goods which he inserts in the AWB or which have been inserted on his behalf.
- The shipper will be liable for all damage suffered by the carrier or other person by reason of the irregularity or incompleteness of the said particulars

# Signatures on AWB

1) shipper's

2) Carrier's

IATA agent is allowed to sign the document twice:

- As handling agent of his customer
- As handling agent of a carrier

With his signature, the shipper simultaneously confirms that he agrees to the Conditions of Contract as set forth on the reverse side of AWB and to the Conditions of Carriage

# AWB number

Airline code Nbr (3 digits)	Serial Nbr (7 digits)	Check digit
<ul style="list-style-type: none"><li>• 657-</li><li>• 020-</li></ul>	<ul style="list-style-type: none"><li>• 1172532</li><li>• 7123216</li></ul>	<ul style="list-style-type: none"><li>• 4</li><li>• 2</li></ul>

657-11725324  
020-71232162

Unweighted Modulus 7 system:

$$\underline{1172532} : 7 = 16704$$

47

52

35

32

4

Remainder used  
for verification

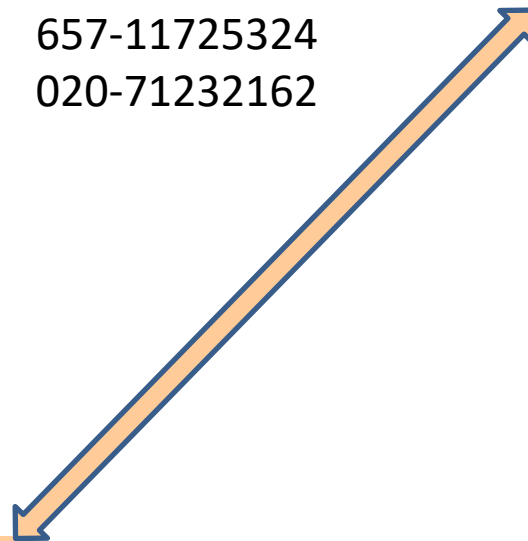

6.2. COMPLETION OF AIR WAYBILL

Shipper's Name and Address (1A, 1, 1B)		Shipper's Account Number (3)		NOT NEGOTIABLE (99)		AIR WAYBILL (99)		ISSUED BY (99)		Copies 1, 2 and 3 of this Air Waybill are originals and have the same validity (1D)		
Consignee's Name and Address (4)		Consignee's Account Number (5)		It is agreed that the goods described herein are accepted in apparent good order and condition (except as noted) for carriage SUBJECT TO THE CONDITIONS OF CONTRACT ON THE REVERSE HEREOF. ALL GOODS MAY BE CARRIED BY ANY OTHER MEANS INCLUDING ROAD OR ANY OTHER CARRIER UNLESS SPECIFIC CONTRARY INSTRUCTIONS ARE GIVEN HEREON BY THE SHIPPER, AND SHIPPER AGREES THAT THE SHIPMENT MAY BE CARRIED VIA INTERMEDIATE STOPPING PLACES WHICH THE CARRIER DEEMS APPROPRIATE. THE SHIPPER'S ATTENTION IS DRAWN TO THE NOTICE CONCERNING CARRIERS' LIMITATION OF LIABILITY. Shipper may increase such limitation of liability by declaring a higher value for carriage and paying a supplemental charge if required. (1E)								
Issuing Carrier's Agent Name and City (6)		Agent's IATA Code (7)		Account No. (8)		Accounting Information (10)						
Airport of Departure (Addr. of First Carrier) and Requested Routing (9)		Reference Number (94A)		Optional Shipping Information (94B)		Declared Value for Carriage (94C)		Declared Value for Customs (94D)				
To (11A)	By First Carrier (11B)	Routing and Destination (11C)	To (11D)	by (11E)	To (11F)	by (11G)	Currency Code (12)	SHGS (13)	WT/VAL (14A)	Other (14B)	Declared Value for Carriage (16)	Declared Value for Customs (17)
Airport of Destination (18)		Requested Flight/Date (19A, 19B)		Amount of Insurance (20)		INSURANCE: If Carrier offers insurance, and such insurance is requested in accordance with the conditions thereof, indicate amount to be insured in figures in box marked 'Amount of Insurance' (20A)						
Handling Information (21)		13		14A		14B		15A		15B		20A
No. of Pieces RCP (22A)		Gross Weight (22B)	kg (22C)	Rate Class (22D)	Commodity Item No. (22E)	Chargeable Weight (22F)	Rate (22G)	Charge (22H)	Total (22I)	Nature and Quantity of Goods (incl. Dimensions or Volume) (22J)		
Prepaid (24A)		Weight Charge (24B)	Collect (24C)	Other Charges (23)								
Valuation Charge (25A)		Tax (26A)		Total Other Charges Due Agent (27A)		Total Other Charges Due Carrier (28A)		Signature of Shipper or his Agent (31)				
Total Prepaid (30A)		Total Collect (30B)		Currency Conversion Rates (32A)		CC Charges in Dest. Currency (32B)		Signature of Issuing Carrier or its Agent (32C)				
For Carrier's use only at Destination (33)		Charges at Destination (33C)		Total Collect Charges (33D)		Executed on (Date) (1A)						
						at (Place) (1B)						

# Completion of AWB



235-85417360

Not Negotiable

## Air Waybill

Issued by **TURKISH AIRLINES INC.**  
**ATATURK HAVALIMANI B KAPISI**  
**KGBT BINASI, ISTANBUL, 34149, TÜRKIYE**

Copies 1, 2 and 3 of this Air Waybill are originals and have the same validity.

Awb # appears in 3 corners on awb

ORIGINAL 3 (FOR SHIPPER)

I.Brasla

# Nosūtītājs/saņēmējs:

235|ATL|85417360



235-85417360

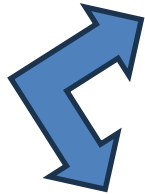

Shipper's Name and Address		Shipper's Account Number	<b>Not Negotiable</b> <b>Air Waybill</b> Issued by TURKISH AIRLINES INC. ATATURK HAVALIMANI B KAPISI KGBT BINASI, ISTANBUL, 34149, TÜRKIYE
DSV ATL Air Import - Firms O293 3705 Wilson Road SE  Atlanta GA 30354 US TE +14047670535 TIM DONALDSON			
Consignee's Name and Address		Consignee's Account Number	Copies 1, 2 and 3 of this Air Waybill are originals and have the same validity.  It is agreed that the goods described herein are accepted in apparent good order and condition (except as noted) for carriage SUBJECT TO THE CONDITIONS OF CONTRACT ON THE REVERSE HEREOF. ALL GOODS MAY BE CARRIED BY ANY OTHER MEANS INCLUDING ROAD OR ANY OTHER CARRIER UNLESS SPECIFIC CONTRARY INSTRUCTIONS ARE GIVEN HEREON BY THE SHIPPER, AND SHIPPER AGREES THAT THE SHIPMENT MAY BE CARRIED VIA INTERMEDIATE STOPPING PLACES WHICH THE CARRIER DEEMS APPROPRIATE. THE SHIPPER'S ATTENTION IS DRAWN TO THE NOTICE CONCERNING CARRIER'S LIMITATION OF LIABILITY. Shipper may increase such limitation of liability by declaring a higher value for carriage and paying a supplemental charge if required.
DSV Latvia SIA - R502 31 KRUSTPILS STR  RIGA 1073 LV TE +37167668300 EORI No.: LV50003420841			
Issuing Carrier's Agent Name and City		Accounting Information	
DSV AIR & SEA INC ATLANTA			
Agent's IATA Code	Account No.		
01-1 9608/0045			

- Maršruts, reisu numuri:

Airport of Departure (Addr. of First Carrier) and Requested Routing							
ATLANTA							
To	By First Carrier	Routing and Destination		to	by	to	by
ORD	TK			IST	TK	RIX	TK
Airport of Destination				Requested Flight/Date			
RIGA				TK6275/13		TK6276/13	
Handling Information TK1757/16							

Issuing Carrier's Agent Name and City DSV AIR & SEA INC ATLANTA						Accounting Information						
Agent's IATA Code 01-1 9608/0045			Account No.									
Airport of Departure (Addr. of First Carrier) and Requested Routing ATLANTA						Reference Number CUS2679630			Optional Shipping Information			
To	By First Carrier	Routing and Destination	to	by	to	by	Currency	CHGS Code	WT/VAL	Other	Declared Value for Carriage	Declared Value for Customs
ORD	TK	IST	TK	RIX	TK	TK	USD	PP	X	X	NVD	NCV
Airport of Destination RIGA		Requested Flight/Date TK6275/13		TK6276/13		Amount of insurance XXX		INSURANCE - If Carrier offers Insurance, and such Insurance is requested in accordance with the conditions thereof, indicate amount to be insured in figures in box marked "Amount of insurance".				
Handling Information TK1757/16												

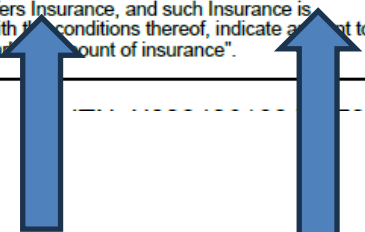

NVD = No Value Declared

NCV = No Customs Value

# Valuation charge

Shippers must declare a Value for Carriage on the air waybill. This declaration may be any amount or **NVD** (No Value Declared)

The Value for Carriage is the airline limit of liability, that is, the amount the airline is liable for should the goods be lost, damaged or delayed.

The airline has to be proved to have been negligent for the liability to be paid.

Limited liability and Valuation Charges are not an insurance and it is recommended that shipments are insured.

Consignments valued at more than SDR 26 per kilo will be assessed Valuation charges of 0.75% of the Shipper's Declared Value for Carriage exceeding SDR 26 per kilo.

to work out Valuation Charges:

1. Multiply gross weight by limited liability to find out the value of the shipment
2. Take the value amount from the declared value for carriage to find the excess amount
3. Multiply the excess by 0.75% to find the Valuation Charge

# Declared value for carriage

To	By First Carrier	Routing and Destination	to	by	to	by	Currency	CHGS Code	WT/VAL	Other	Declared Value for Carriage	Declared Value for Customs
ORD	TK	IST TK RIX TK	USD	PP	X	X	USD	PP	X	X	NVD	NCV
RIGA		TK6275/13		TK6276/13		XXX		<small>INSURANCE - If Carrier offers Insurance, and such Insurance is requested in accordance with the conditions thereof, indicate amount to be declared in figures in box marked "amount of insurance".</small>				
Handling Information TK1757/16 8 PACKAGES DANGEROUS GOODS AS PER ASSOCIATED SHIPPER'S DECLARATION										ITN: X20240612214170		
												SCI
No. Of Pieces RCP	Gross Weight	kg	Rate Class	Chargeable Weight	Rate	Charge	Total	Nature and Quantity of Goods (incl. Dimensions or Volume)				
10	45.80	K	Q	57.0	6.48		364.80	Consolidation as per attached list HS Code: 291411 HS Code: 321410 HS Code: 390730 HS Code: 320890 HS Code: 391910 HS Code: 392190 HS Code: 350691 HS Code: 391000 VOL 0.341 M3				
10	45.80						364.80					
Prepaid		Weight Charge		Collect		Other Charges						
		364.80				RAC CARRIER DANGEROUS GOODS FEE 600.00 AWC AWB (AIR WAYBILL) 4.00						
		Valuation Charge										
		Tax										
		Total Other Charges Due Agent						Shipper certifies that the particulars on the face hereof are correct and that insofar as any part of the consignment contains dangerous goods, such part is properly described by name and is in proper condition for carriage by air according to the applicable Dangerous Goods Regulations.				
		Total Other Charges Due Carrier										
		604.00										

e 1 Jul 10) compliant Laser Air Waybill

TIMOTHY THOMPSON

I.Brasla

Issuing Carrier's Agent Name and City (6)				Accounting Information (10)								
Agent's IATA Code (7)			Account No. (8)									
Airport of Departure (Addr. of First Carrier) and Requested Routing (9)						Reference Number (34A)		Optional Shipping Information (34B)				(34C)
To (11A)	By First Carrier	Routing and Destination (11B)	to (11C)	by (11D)	to (11E)	by (11F)	Currency (12)	CHGS Code	WT/VAL PPD COLL	Other PPD COLL	Declared Value for Carriage (16)	Declared Value for Customs (17)
Airport of Destination (18)			Requested Flight/Date (19A) (19B)			Amount of Insurance (20)			INSURANCE: If Carrier offers insurance, and such insurance is requested in accordance with the conditions thereof, indicate amount to be insured in figures in box marked 'Amount of Insurance'			
Handling Information (21)						(13)	(14A)	(14B)	(15A)	(15B)	(20A)	(21A) SCI
No. of	Class	Rate Class										

SCI (Special Customs Information):

C

X

T1

T2L

Is applied to consignments loaded in EU country only (Customs Origin Code)

Airport of Departure (Addr. of First Carrier) and Requested Routing RIGA					Reference Number								
To	By First Carrier	Routing and Destination	to	by	to	by	Currency	CHGS Code	WT/VAL PPD COLL	Other PPD COLL	Declared Value for Carriage	D	Customs
TLV	AIR	BALTIC							X	X	NVD		
Airport of Destination			Requested Flight/Date			Amount of Insurance		INSURANCE - If carrier offers insurance, and requested in accordance with the conditions thereof to be insured in figures in box marked "Amount of Ins					
TEL AVIV			BT771/24JUL			XXX							
Handling Information DANGEROUS GOODS AS PER ASSOCIATED DGD													
											SCI	X	
											TLV		

## SCI (Special Customs Information):

C

EU cargo moving within EU

X

EU cargo leaving EU

T1

transit

T2L

Goods having Community status (proof)

Kādēļ šajā AWB šis lodziņš tukšs?

To	By First Carrier	Routing and Destination	to	by	to	by	Currency	CHGS Code	WT/VAL	Other	Declared Value for Carriage	Items
ORD	TK	IST TK RIX TK	USD	PP	X	X	NVD					
RIGA		TK6275/13		TK6276/13		XXX		INSURANCE - If Carrier offers Insurance, and such Insurance requested in accordance with the conditions thereof, indicate the amount insured in figures in box marked "amount of insurance".				
Handling Information TK1757/16											ITN: X202406122141	
8 PACKAGES DANGEROUS GOODS AS PER ASSOCIATED SHIPPER'S DECLARATION											SCI	
No. Of Pieces RCP	Gross Weight	kg	Rate Class	Chargeable Weight	Rate	Charge	Total	Nature and Quantity of Goods (incl. Dimensions or Volume)				
10	45.80	K	Q	57.0	6.40		364.80	Consolidation as per attached list HS Code: 291411 HS Code: 321410 HS Code: 390730 HS Code: 320890 HS Code: 391910 HS Code: 392190 HS Code: 350691 HS Code: 391000 VOL 0.341 M3				
10	45.80						364.80					
Prepaid		Weight Charge		Collect		Other Charges		RAC CARRIER DANGEROUS GOODS FEE 600.00				
		364.80				AWC AWB (AIR WAYBILL)		4.00				
		Valuation Charge										
		Tax										
		Total Other Charges Due Agent										
		Total Other Charges Due Carrier				604.00		Shipper certifies that the particulars on the face hereof are correct and that insofar as any part of the consignment contains dangerous goods, such part is properly described by name and is in proper condition for carriage by air according to the applicable Dangerous Goods Regulations.				

e 1 Jul 10) compliant Laser Air Waybill

I.Brasla  
TIMOTHY THOMPSON

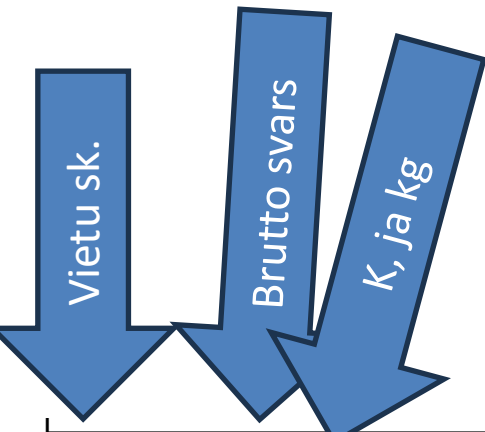

No. Of Pieces RCP	Gross Weight	Kg lb	Rate Class		Chargeable Weight	Rate		Total	Nature and Quantity of Goods (incl. Dimensions or Volume)
			Commodity Item No.			Charge			
10	45.80	K	Q		57.0	6.40		364.80	Consolidation as per attached list HS Code: 291411 HS Code: 321410 HS Code: 390730 HS Code: 320890 HS Code: 391910 HS Code: 392190 HS Code: 350691 HS Code: 391000 VOL 0.341 M3
10	45.80							364.80	

# Air Cargo Rating (2)

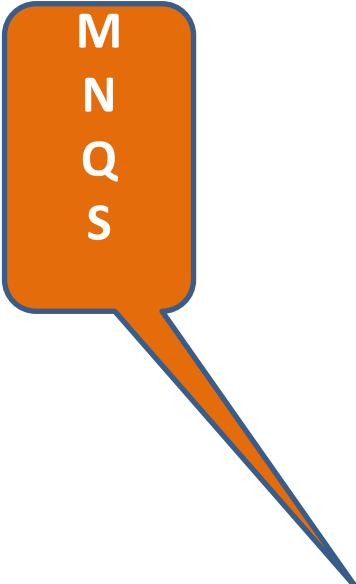

There are following **rates codes**:

- M** = Minimum charges
- N** = Normal rate (under 45 kgs)
- Q** = Quantity rates (+45, +100, +300, 500 kgs)
- S** = Surcharges

N, Q =  
General  
Cargo Rates

Class Rates  
(AVI, HUM,  
VAL)

No. Of Pieces RCP	Gross Weight	kg lb	Rate Class		Chargeable Weight	Rate		Total	Nature and Quantity of Goods (incl. Dimensions or Volume)
			Commodity Item No.			Charge			
10	45.80	K	Q		57.0	6.40	364.80	Consolidation as per attached list HS Code: 291411 HS Code: 321410 HS Code: 390730 HS Code: 320890 HS Code: 391910 HS Code: 392190 HS Code: 350691 HS Code: 391000 VOL 0.341 M3	
10	45.80					I.Brasla	364.80		

$$57 \times 6.40 = 364.80$$

No. Of Pieces RCP	Gross Weight	kg lb	Rate Class		Chargeable Weight	Rate		Total	Nature and Quantity of Goods (incl. Dimensions or Volume)
			Commodity Item No.			Charge			
10	45.80	K	Q		57.0	6.40	364.80	Consolidation as per attached list HS Code: 291411 HS Code: 321410 HS Code: 390730 HS Code: 320890 HS Code: 391910 HS Code: 392190 HS Code: 350691 HS Code: 391000 VOL 0.341 M3	
10	45.80						364.80		

No. Of Pieces RCP	Gross Weight	kg lb	Rate Class		Chargeable Weight	Rate		Total	Nature and Quantity of Goods (incl. Dimensions or Volume)
			Commodity Item No.			Charge			
10	45.80	K	Q		57.0	6.40		364.80	Consolidation as per attached list HS Code: 291411 HS Code: 321410 HS Code: 390730 HS Code: 320890 HS Code: 391910 HS Code: 392190 HS Code: 350691 HS Code: 391000 VOL 0.341 M3
10	45.80							364.80	
Prepaid			Weight Charge		Collect		Other Charges		
			364.80				RAC CARRIER DANGEROUS GOODS FEE 600.00 AWC AWB (AIR WAYBILL) 4.00		
			Valuation Charge						
			Tax						
			Total Other Charges Due Agent				Shipper certifies that the particulars on the face hereof are correct and that insofar as any part of the consignment contains dangerous goods, such part is properly described by name and is in proper condition for carriage by air according to the applicable Dangerous Goods Regulations.		
			Total Other Charges Due Carrier						
			604.00						



Charges may be either 'prepaid' or 'collect'

To	By First Carrier	Routing and Destination	to	by	to	by	Currency	CHGS Code	WT/VAL	Other	Declared Value for Carriage	Declared Value for Customs
ORD	TK	IST TK RIX TK	USD	PP	X	X	USD	PP	X	X	NVD	NCV
RIGA		TK6275/13		TK6276/13		XXX		INSURANCE - If Carrier offers Insurance, and such Insurance is requested in accordance with the conditions thereof, indicate amount to be insured in figures in box marked "amount of insurance".				
Handling Information TK1757/16											ITN: X20240612214170	
8 PACKAGES DANGEROUS GOODS AS PER ASSOCIATED SHIPPER'S DECLARATION											SCI	
No. Of Pieces RCP	Gross Weight	kg	Rate Class	Chargeable Weight	Rate	Charge	Total	Nature and Quantity of Goods (incl. Dimensions or Volume)				
10	45.80	K	Q	57.0	6.40		364.80	Consolidation as per attached list HS Code: 291411 HS Code: 321410 HS Code: 390730 HS Code: 320890 HS Code: 391910 HS Code: 392190 HS Code: 350691 HS Code: 391000 VOL 0.341 M3				
10	45.80						364.80					
Prepaid		Weight Charge		Collect		Other Charges						
364.80						RAC CARRIER DANGEROUS GOODS FEE 600.00 AWC AWB (AIR WAYBILL) 4.00						
Valuation Charge												
Tax												
Total Other Charges Due Agent												
Total Other Charges Due Carrier												
604.00												
Shipper certifies that the particulars on the face hereof are correct and that insofar as any part of the consignment contains dangerous goods, such part is properly described by name and is in proper condition for carriage by air according to the applicable Dangerous Goods Regulations.												
I.Brasla												
TIMOTHY THOMPSON												

To	By First Carrier	Routing and Destination	to	by	to	by	Currency	WT/VAL	Other	Declared Value for Carriage	Declared Value for Customs
ORD	TK		IST	TK	RIX	TK	USD	PP X	X	NVD	NCV
Airport of Destination		Requested Flight/Date		Amount of Insurance		INSURANCE - If Carrier offers Insurance, and such Insurance is requested in accordance with the conditions thereof, indicate amount to be insured in figures in box marked "amount of insurance".					
RIGA		TK6275/13 TK6276/13		XXX							
Handling Information TK1757/16										ITN: X20240612214170	
8 PACKAGES DANGEROUS GOODS AS PER ASSOCIATED SHIPPER'S DECLARATION										SCI	
No. Of Pieces RCP	Gross Weight	kg lb	Rate Class	Commodity Item No.	Chargeable Weight	Rate	Charge	Total	Nature and Quantity of Goods (incl. Dimensions or Volume)		
10	45.80	K	Q		57.0		6.40	364.80	Consolidation as per attached list HS Code: 291411 HS Code: 321410 HS Code: 390730 HS Code: 320890 HS Code: 391910 HS Code: 392190 HS Code: 350691 HS Code: 391000 VOL 0.341 M3		
10	45.80							364.80			
Prepaid			Weight Charge			Collect			Other Charges		
			364.80						RAC CARRIER DANGEROUS GOODS FEE 600.00		
			Valuation Charge						AWC AWB (AIR WAYBILL) 4.00		
			Tax								
			Total Other Charges Due Agent						Shipper certifies that the particulars on the face hereof are correct and that insofar as any part of the consignment contains dangerous goods, such part is properly described by name and is in proper condition for carriage by air according to the applicable Dangerous Goods Regulations.		
			Total Other Charges Due Carrier								
			604.00						TIMOTHY THOMPSON 		

Prepaid (24A)	Weight Charge (24B)	Collect (24B)	Other Charges (23)
Valuation Charge (25A) (25B)			
Tax (26A) (26B)			
Total Other Charges Due Agent (27A) (27B)		Shipper certifies that the particulars on the face hereof are correct and that <b>insofar as any part of the consignment contains dangerous goods, such part is properly described by name and is in proper condition for carriage by air according to the applicable Dangerous Goods Regulations.</b>  ..... Signature of Shipper or his Agent	
Total Other Charges Due Carrier (28A) (28B)			
Total Prepaid (29A)	Total Collect (29B)		
Currency Conversion Rates (30A)	CC Charges in Dest. Currency (30B)	(32A)	(32B) (32C)
For Carrier's use only at Destination (33)	Charges at Destination (33B) (33C)	Executed on (Date) (33D)	Signature of Issuing Carrier or its Ag (1A) (1B)

ORIGINAL 3 (FOR SHIPPER)

Due carrier:

MYC

SCC

RAC

LAC

Due agent:

AWA

CHA

PUA

MMA

Resolution 600b (Effective 1 Jul 10) compliant Laser Air Waybill

Prepaid	Weight Charge	Collect	
	364.80		Other Charges RAC CARRIER DANGEROUS GOODS FEE 600.00 AWC AWB (AIR WAYBILL) 4.00
	Valuation Charge		
	Tax		
	Total Other Charges Due Agent		Shipper certifies that the particulars on the face hereof are correct and that insofar as any part of the consignment contains dangerous goods, such part is properly described by name and is in proper condition for carriage by air according to the applicable Dangerous Goods Regulations.
	Total Other Charges Due Carrier		
	604.00		
		TIMOTHY THOMPSON	
		Signature of Shipper or his Agent	
Total Prepaid	Total Collect		
968.80			
Currency Conversion Rates	CC. Charges in Dest. Currency	12-Jun-24	ATLANTA
		Executed on (date)	at (place)
	Charges at Destination	Total Collect Charges	DSV AIR & SEA INC
For Carrier's use only at Destination			Signature of Issuing Carrier or its Agent
			235-85417360

**Original 2 - (for Consignee)**

# Please fill in the AWB extract!

1. A consignment consisting of  
 8 kgs of documents,  
 dims 30 x 25 x 27 cms, is  
 shipped from New York to Tallinn

Rates: M = 100.00  
 N = 9.97  
 45 = 8.17  
 100 = 6.00

No of pieces	Gross weight	kg lb	Rate Class		Chargeable weight	Rate	TOTAL	Nature & Qty of goods (incl.dimensions or volume)
			Commodity Item No.					
RCP								

# Please fill in the AWB extract - atbilde

1. A consignment consisting of  
 8 kgs of documents,  
 dims 30 x 25 x 27 cms, is  
 shipped from New York to Tallinn

Rates: M = 100.00  
 N = 9.97  
 45 = 8.17  
 100 = 6.00

No of pieces RCP	Gross weight	kg lb	Rate Class		Chargeable weight	Rate / Charge		TOTAL	Nature & Qty of goods (incl.dimensions or volume)
			Commodity Item No.						
1	8	k	M		8	100	100	100	Documents 30 x 25 x 27 cm
1	8							100	

## 2. RIGA – SALZBURG

4 pieces total weight 40 kgs electricals

Dims: 45 x 40 x 40 cms each

Rates available: M 43    N 1.95    45 1.75    100 1.55

No of pieces RCP	Gross weight	kg lb	Rate Class		Chargeable weight	Rate Charge	TOTAL	Nature & Qty of goods (incl.dimensions or volume)
				Commodity Item No.				

# Atbilde

## 2. RIGA – SALZBURG

4 pieces total weight 40 kgs electricals

Dims: 45 x 40 x 40 cms each

Rates available: M 43    N 1.95    45 1.75    100 1.55

No of pieces RCP	Gross weight	kg lb	Rate Class		Chargeable weight	Rate Charge	TOTAL	Nature & Qty of goods (incl.dimensions or volume)
				Commodity Item No.				
4	40	K	Q		48	1.75	84	electricals, not restricted
4	40						84	

# Sūtījuma izmaksu aprēķināšana



## forwarder

- p/u
- wh
- packing/labelling
- awb
- CUS
- insurance



## airport terminal:

- exp.THG
- X-ray
- acceptance of spec.cargo



## airline /GSSA

- airfreight
- surcharges (MYC+SCC)
- spec.cargo fees



## airport terminal:

- import THG
- storage



## forwarder

- imp.CUS
- docs
- delivery

Svarīgi zināt klientu savstarpējo vienošanos (INCOTERMS)

# Sūtījuma izmaksu aprēķins (2)



## forwarder

- p/u
- wh
- packing/labelling
- **awb**
- CUS
- insurance



## airport terminal:

- exp.THG
- X-ray
- acceptance of spec.cargo



## airline /GSSA

- airfreight
- surcharges (MYC+SCC)
- spec.cargo fees



## airport terminal:

- import THG
- storage



## forwarder

- imp.CUS
- docs
- delivery



150kg  
RIX-NYC

# Sūtījuma izmaksu aprēķins (3)

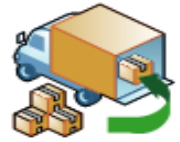

**forwarder**

- p/u
- wh
- packing/labelling
- awb
- CUS
- insurance

**airport terminal:**

- exp.THG
- X-ray
- acceptance of spec.cargo

**airline /GSSA**

- airfreight
- surcharges (MYC+SCC)
- spec.cargo fees

**airport terminal:**

- import THC
- storage

**forwarder**

- imp.CUS
- docs
- delivery

30.00

5.70+12.75+  
1.43= 19.88

1.45+1.10+0.15  
=2.70/kgx150 =  
405.00 + profit

AIRPORT

AIRPORT



**forwarder**

- p/u
- wh
- packing/labelling
- awb
- CUS
- insurance



**airport terminal:**

- exp.THG
- X-ray
- acceptance of spec.cargo



**airline /GSSA**

- airfreight
- surcharges (MYC+SCC)
- spec.cargo fees



**airport terminal:**

- import THG
- storage



**forwarder**

- imp.CUS
- docs
- delivery

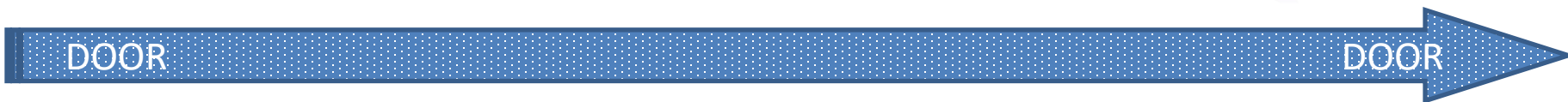



**forwarder**

- p/u
- wh
- packing/labelling
- awb
- CUS
- insurance



**airport terminal:**

- exp.THG
- X-ray
- acceptance of spec.cargo



**airline /GSSA**

- airfreight
- surcharges (MYC+SCC)
- spec.cargo fees



**airport terminal:**

- import THG
- storage



**forwarder**

- imp.CUS
- docs
- delivery

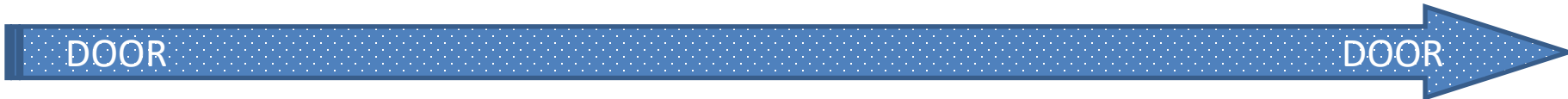
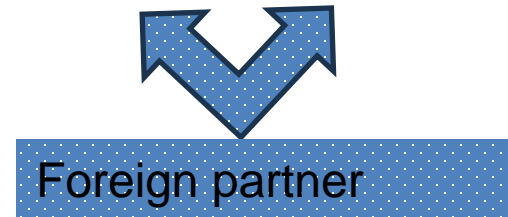

# Secinājumi par gaisa transportu

- Ātrs
- Drošs
- Dārgs
- Nav labākais risinājums apjomīgām un/vai lētām precēm
- Ieteicams ātri 'bojājošamies' precēm
- Ierobežota vieta
- Ierobežoti bagāžas nodalījumu durvju izmēri
- Transportēšana no lidostas līdz lidostai

**Nedeklarētās  
bīstamās kravas  
– drauds  
aviācijas drošībai**



- Vai mums apkārt daudz bīstamu lietu/preču, kas var būt bīstamas transportējot?
- Nosauciet kādus piemērus!





**Lawn Fertilizer**  
**12-3-10**

**NITROGEN** (symbol N) for shoot growth and green color.

**PHOSPHORUS** (symbol P) for root growth and cellular functioning.

**POTASSIUM** (symbol K), sometimes called potash, for root development, improved stress tolerance and disease resistance.

For example, a 100-pound bag marked "12-3-10" has 12 pounds of nitrogen (12%), 3 pounds of phosphorus (3%) and 10 pounds of potassium (10%). The remaining 75 pounds are made up of other nutrients, conditioners and fillers. Their purpose is to help distribute the fertilizer evenly and prevent chemical burn.

Nitrogen and phosphorus may cause water pollution if misapplied.



## Kādā veidā kaut kas bīstams var nonākt gaisa kuģī?

- Vai drīkst pārvadāt bīstamas lietas transportā, it īpaši gaisa kuģos?
- Kādi apstākļi iedarbojas uz kravām lidojuma laikā?

# Kādā veidā kaut kas bīstams var nonākt gaisa kuģī?



Gaisa kuģa  
darbības  
nodrošināšanai



pasažieru  
un  
ekipāžas  
bagāžā



Pasta  
sūtījumos



kravās

Bīstamas preces

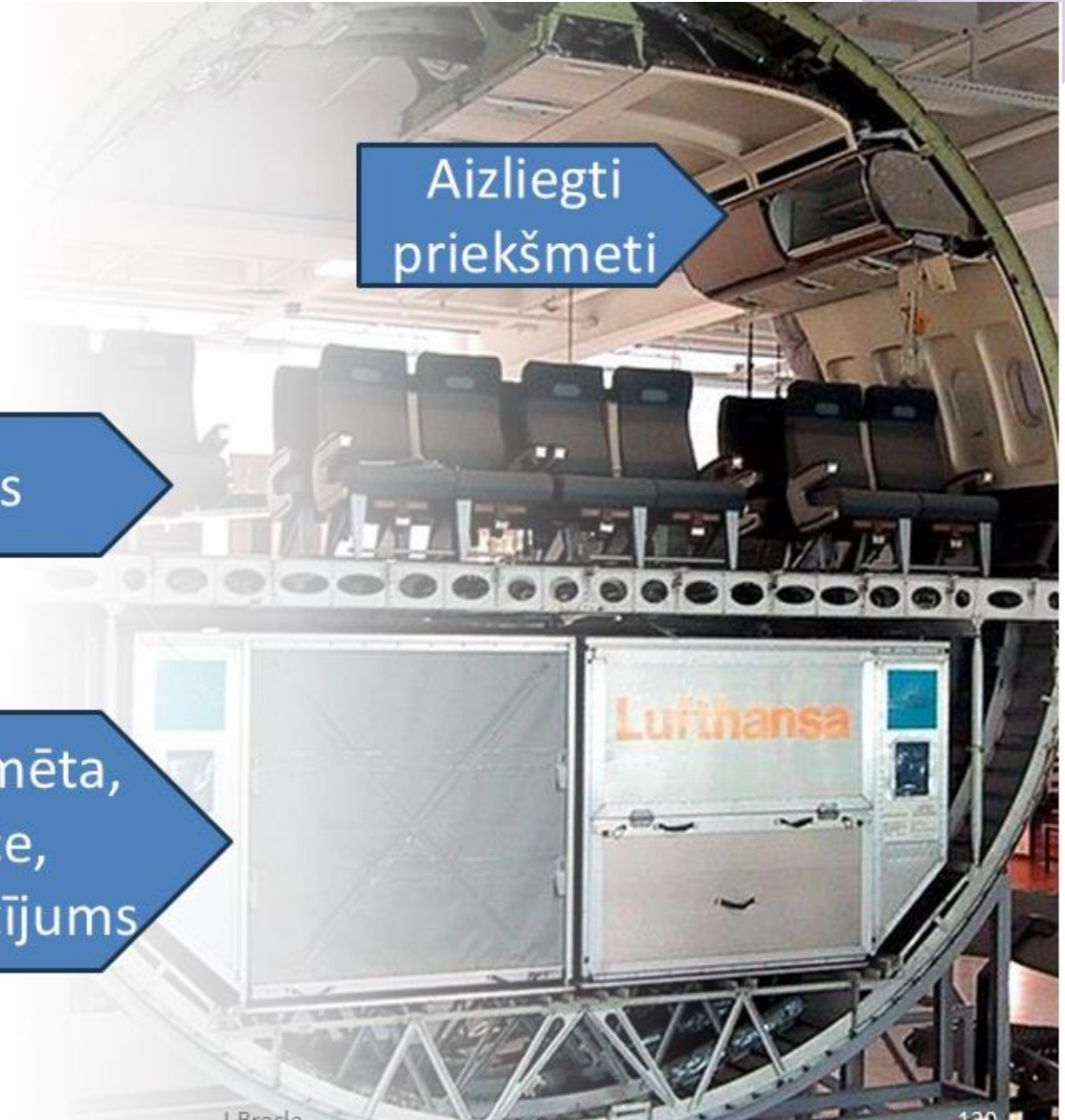
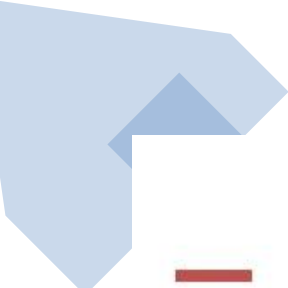

Aizliegti priekšmeti

Mēs

Nepareizi noformēta, iepakota prece, bagāža, pasta sūtījums



# Bīstamās preces

Bīstamu preču transportēšana ir strikti regulēta joma, lai pēc iespējas nepieļautu negadījumus, kas ietekmētu pasažieru veselību vai pat dzīvību, nebojātu īpašumu (gaisa kuģi, citas kravas) vai apkārtējo vidi.

- ADR
- IMDG
- DGR
- RID



# Regulatory Framework

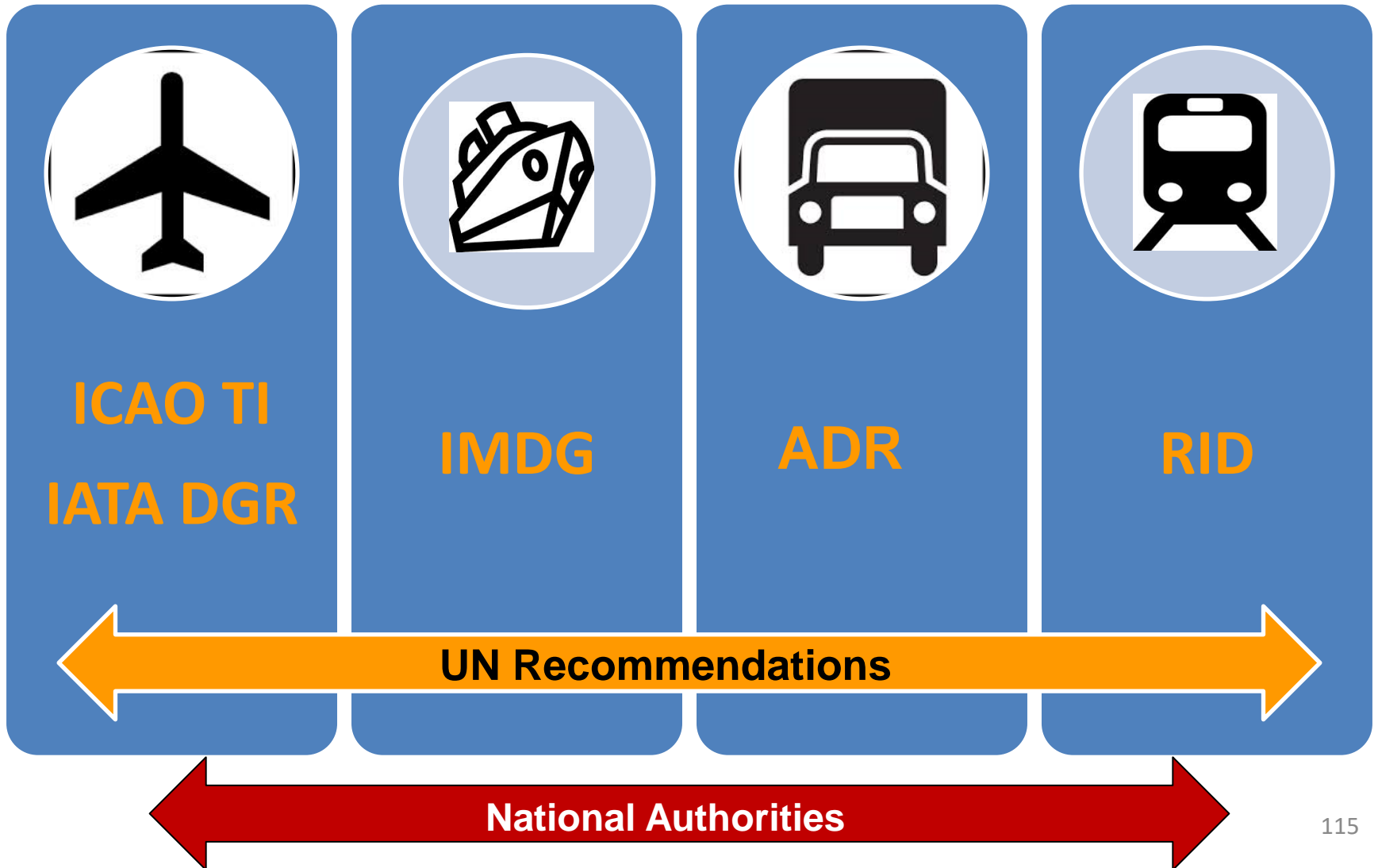

# ICAO and IATA

ICAO ir izstrādājusi tehniskās instrukcijas par bīstamu izstrādājumu transportēšanu gaisa transportā un katrus 2 gadus tie tiek pārskatīti.



Doc 9284

Technical Instructions for the Safe Transport of Dangerous Goods by Air

2025-2026 Edition

Approved and published by decision of the Council of ICAO

INTERNATIONAL AVIATION ORGANIZATION



Effective 1 January - 31 December 2025  
Produced in consultation with ICAO

**Dangerous Goods  
Regulations (DGR)**  
Edition 66

The guide recognized by the world's airlines



Balstoties uz ICAO TI, IATA ir izstrādājusi Bīstamu kravu noteikumus, kas tiek izmantoti kā ikdienas darba dokuments un tiek publicēti katru gadu.

I.Brasla

# Visiem iesaistītajiem jābūt apmācītiem saskaņā ar savām darba funkcijām



## Dangerous Goods Training Program Management under CBTA approach

IATA Dangerous Goods training is evolving from traditional learning to competency-based training and assessment (CBTA) as agreed by ICAO. Find the right DG course for your specific job function.

CBTA DGR Reference **7.1-7.10**

### Freight Forwarders

GENERAL CARGO ACCEPTANCE  
7.2

CARGO SCREENING  
7.10

DG PROCESSING  
7.3

CARGO HANDLING/LOADING  
7.4

LABORATORIES/HEALTH SERVICES  
ISSO

BATTERIES AND BATTERY PRODUCTS  
LBSR

### Shippers & Packers

SHIPPER/MANUFACTURERS  
7.1

### Operators & Ground Service Providers

BAGGAGE SCREENING  
7.10

GENERAL CARGO ACCEPTANCE  
7.2

CARGO HANDLING/LOADING  
7.4

PASSENGERS HANDLING  
7.5

DG ACCEPTANCE  
7.3

LOAD PLANNING  
7.6

CABIN CREW  
7.9

FLIGHT OPERATIONS/DISPATCHER  
7.8

FLIGHT CREW  
7.7

CARGO SCREENING  
7.10



Instructional Designers



Trainer/Instructors



Instructor Refresher

### Dangerous Goods Training Program Management

This pictogram is for illustrative purposes only and may not be an exact representation of DG preparation, handling and shipping processes.

# Likumdošana Latvijā

- Bīstamo kravu aprites likums

<http://likumi.lv/doc.php?id=220516>

- nosaka valsts kompetences jautājumus attiecībā uz visu veidu bīstamo kravu apriti un jebkuru tajā iesaistīto bīstamo kravu aprites dalībnieku, kā arī bīstamo kravu aprites kontroles un uzraudzības mehānismu

**bīstamo kravu aprites dalībnieks** — bīstamo kravu aprītē iesaistīta fiziskā persona, juridiskā persona vai personu apvienība. Bīstamo kravu aprites dalībnieki ir kravas nosūtītājs, saņēmējs, iekrāvējs, izkrāvējs, iepakotājs, iepildītājs, pārvadātājs,

- Likums «**Par aviāciju**»

<https://likumi.lv/ta/id/57659-par-aviaciju>

- 121.pants **Administratīvie pārkāpumi bagāžas, pasta un kravas gaisa pārvadājumu jomā**

Par bīstamu izstrādājumu vai vielu pārvadāšanas noteikumu pārkāpšanu gaisa transportā piemēro brīdinājumu vai naudas sodu juridiskajām personām no trīssimt līdz tūkstoš sešsimt naudas soda vienībām\* (=līdz 8000 EUR).

\*1 naudas soda vienība 5 EUR

## **Bīstamo izstrādājumu un bīstamo kravu gaisa pārvadājumu veikšanas kārtība**

Jaunā pilnībā pārstrādātā  
2008.g.noteikumu versija

1. Noteikumi nosaka kārtību, kādā:

1.1. veic bīstamo izstrādājumu un bīstamo kravu sagatavošanu pārvadāšanai ar gaisa kuģi un pārvadāšanu ar gaisa kuģi, tai skaitā:

1.1.1. bīstamo kravu aprites dalībnieku pienākumus gaisa pārvadājumu jomā un kārtību, kādā uzrauga šo pienākumu izpildi;

1.1.2. bīstamo kravu gaisa pārvadājumu apstiprinājumu izsniegšanas, apturēšanas un anulēšanas kārtību;

1.1.3. kārtību, kādā izsniedz apmācības sniedzēju un instruktoru sertifikātu gaisa pārvadājumu jomā, kā arī sertifikātu pagarināšanas, apturēšanas, anulēšanas, izmantošanas un atzīšanas kārtību;

1.1.4. kārtību, kādā apmāca darbiniekus, kuri iesaistīti bīstamo kravu aprītē gaisa pārvadājumu jomā;

1.1.5. kārtību, kādā informē pasažierus par gaisa pārvadājumos aizliegtiem bīstamajiem izstrādājumiem;

1.1.6. kārtību, kādā izmeklē bīstamo kravu nedeklarētu pārvadāšanu gaisa kuģos;

1.2. ziņo par tādiem atgadījumiem civilajā aviācijā, kuri skar bīstamo kravu gaisa pārvadājumus.

## **Bīstamo izstrādājumu un bīstamo kravu gaisa pārvadājumu veikšanas kārtība**

2. Noteikumu prasības attiecas uz:

2.1. bīstamo kravu aprites dalībniekiem, kas **nosūta bīstamās kravas** un **pasta sūtījumus**, kuri satur bīstamos izstrādājumus un kurus atļauts pārvadāt ar gaisa kuģi;

2.2. bīstamo kravu aprites dalībniekiem, kas **piedāvā un sniedz starpniecības pakalpojumus** – bīstamu kravu un pasta sūtījumu sagatavošanu pārvadāšanai ar gaisa kuģi;

2.3. Latvijas Republikā reģistrētajiem **gaisa kuģu ekspluatantiem** neatkarīgi no tā, vai tie veic bīstamu kravu un bīstamu izstrādājumu gaisa pārvadājumus Latvijas Republikā vai ārvalstīs;

2.4. ārvalstīs reģistrētajiem gaisa kuģu ekspluatantiem, ja tie veic bīstamu kravu gaisa pārvadājumus no un uz Latvijas Republikas lidlaukiem vai Latvijas Republikas gaisa telpā;

2.5. civilās aviācijas lidlauku ekspluatantiem (turpmāk – lidlauka ekspluatants), izņemot lidlauka ekspluatantus vispārējās aviācijas lidlaukos;

...

2.8. gaisa kuģu **virszemes apkalpošanas pakalpojumu sniedzējiem**

Kas ir atbildīgs par bīstamās kravas identifikāciju, iepakojšanu, sagatavošanu transportēšanai?

I: Aviolīnija

II: Kravu ekspeditors

III: Nosūtītājs

IV: DHL Kurjers

# Atbilde:

Kas ir atbildīgs par bīstamās kravas identifikāciju, iepakojšanu, sagatavošanu transportēšanai?

I: Avioliņija

II: Kravu ekspeditors

III: Nosūtītājs

IV: DHL Kurjers

# Nosūtītāja atbildības:

Pirms jebkuras bīstamo preču kravas nosūtīšanas darba devējam jānodrošina, ka darbinieki ir informēti par viņu atbildībām attiecībā uz šo preču transportēšanu:

- Precēm jābūt pareizi:
  - identificētām,
  - klasificētām,
  - iepakotām,
  - marķētām un aplīmētām
  - dokumentētām
- Visām iesaistītajām personām jābūt apmācītām saskaņā ar viņu darba funkcijām

# Bīstamo vielu/izstrādājumu klasifikācija

Bīstamās preces (gan vielas, gan gatavie izstrādājumi) ir iedalītas **9 klasēs** (*Class*) atbilstoši bīstamības veidam, *piem.uzliesmojošs šķidrums vai cieta viela, kodīga viela*

Dažas klases ( 1., 2., 4., 5., 6.) ir sadalītas **apakšklasēs**, lai precīzāk identificēto iespējamo bīstamību

- Klases apzīmē ar vienu ciparu, piem.7.klase
- Apakšklases ar diviem cipariem, piem Apakšklase 4.1

# Visu 9 bīstamības klašu un apakšklašu bīstamības zīmes

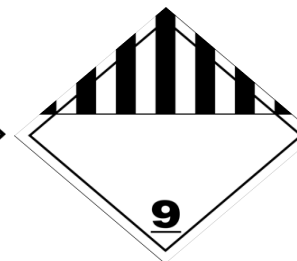

# Visas 9 bīstamības klases

- **Class 1 – Sprāgstvielas**

(6 apakšklases)



- **Class 2 – Gāzes**

- Division 2.1 - Uzliesmojošas— sajaucoties gaisu veido uzliesmojošu maisījumu

- Division 2.2 - Neuzliesmojošas— (t.sk.neindīgas, atdzesētas)

- Divison 2.3 - Indīgas-

Indīgas vai kodīgas cilvēkiem



- **Class 3 – Uzliesmojoši šķidrumi**



- **Class 4 – Uzliesmojošas cietas vielas**



**Division 4.1** –uzliesmojošas cietas vielas, dažas - pašreaģējošas

- **Division 4.2** - vielas ar spontānas aizdegšanās risku
- Division 4.3** - cietas vielas, kas izdala uzliesmojošas gāzes kontaktā ar ūdeni



– **Division 5.1** – Oksidētāji



– **Division 5.2** - Organiskie peroksīdi (termiski nestabili)



- Class 6
  - **Division 6.1 – Indīgas vielas**
  - **Division 6.2 – Infekciozas vielas**

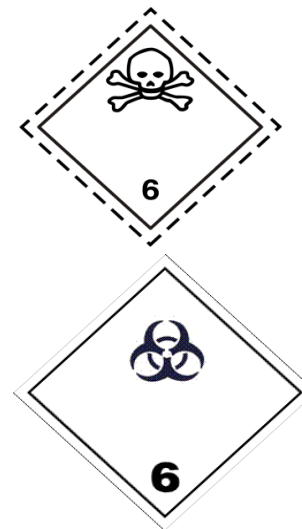

- **Class 7 - Radioaktīvie Materiāli**

- Category I white
- Category II yellow
- Category III yellow



- **Class 8 – Kodīgas vielas**

- **Class 9 – Dažādas (pārējās) bīstamas preces-**  
(kas nav iekļautas citās klasēs)

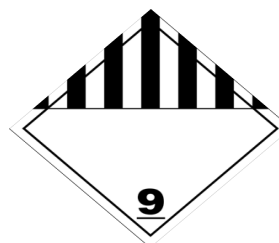

**Kuri no šiem objektiem varētu būt bīstami transportējot?**





**Lawn Fertilizer**  
**12-3-10**

- NITROGEN** (symbol N) for shoot growth and green color.
- PHOSPHORUS** (symbol P) for root growth and cellular functioning.
- POTASSIUM** (symbol K), sometimes called potash, for root development, improved stress tolerance and disease resistance.

For example, a 100-pound bag marked "12-3-10" has 12 pounds of nitrogen (12%), 3 pounds of phosphorus (3%) and 10 pounds of potassium (10%). The remaining 75 pounds are made up of other nutrients, conditioners and fillers. Their purpose is to help distribute the fertilizer evenly and prevent chemical burn.

Nitrogen and phosphorus may cause water pollution if misapplied.



# Slēptās/ nedeklarētās bīstamās preces

Iemesls 80% visu negadījumu, kas saistīti ar bīstamajām kravām, ir nedeklarētas bīstamās kravas



## Kādi varētu būt iemesli?

Zināšanu trūkums

- likumi
- DGR

Līdzekļu taupīšana:

- apmācības
- Spec.iepakojumi
- Transp.izmaksas

Atbildības trūkums

# Kāda ir terminālu loma, atbildības un kādi uzdevumi attiecībā uz bīstamiem priekšmetiem vai vielām

- Drošības pārbaudes pasažieriem un viņu bagāžai
- Pasta sūtījumu kontrole
- Kravu akceptēšanas procedūra

# Minimālā nepieciešamā informācija par bīstamo kravu, lai rezervētu vietu gaisa kuģī

- *Proper Shipping name*
- *UN number*
- *Packing Group (if applicable)*
- *Quantities to be shipped  
(per inner/outer packagings)*
- *Type of outer packaging(s)*

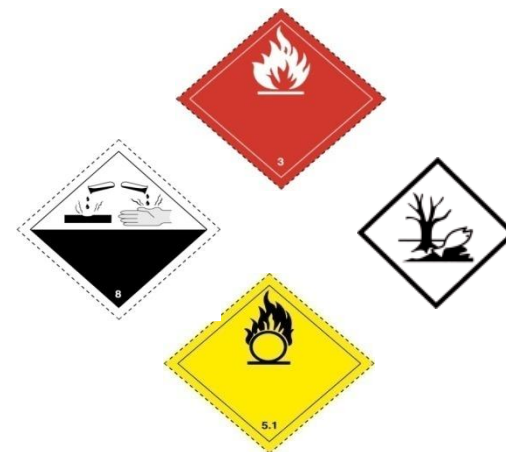

**Chromic acid solution**

UN1755 PG III

0.5 L /inner

3 L/ outer



packaging

Lielākajai daļai bīstamo  
kravu sūtījumu tiek  
sagatavota bīstamās  
kravas deklarācija

Tā ir nosūtītāja atbildība  
sagatavot šo dokumentu  
un apstiprināt, ka sūtījums  
pilnībā atbilst noteikumu  
prasībām

## Shipper's Declaration for Dangerous

SHIPPER'S DECLARATION FOR DANGEROUS GOODS						
Shipper SONIC TRANSPORT SIA KATLAKALNA 9A RIGA, LV-1073 LATVIA			Air Waybill No. 657-12345678 Page 1 of 1 Pages Shipper's Reference Number (optional)			
Consignee FIXER MASTERS GMBH NEUE GRUNSTRASSE 39, BERLIN, DE-10179 GERMANY			SONIC TRANSPORT SIA RIGA			
Two completed and signed copies of this Declaration must be handed to the operator			<b>WARNING</b> Failure to comply in all respects with the applicable Dangerous Goods Regulations may be in breach of the applicable law, subject to legal penalties.			
TRANSPORT DETAILS						
This shipment is within the limitations prescribed for: (delete non applicable)			Airport of Departure (optional) RIGA			
<input checked="" type="checkbox"/> PASSENGER <input checked="" type="checkbox"/> CARGO <input checked="" type="checkbox"/> AIRCRAFT <input checked="" type="checkbox"/> ONLY			CARGO AIRCRAFT ONLY			
Airport of Destination (optional) BERLIN			Shipment type (delete non-applicable) <input type="checkbox"/> NON-RADIOACTIVE <input checked="" type="checkbox"/>			
NATURE AND QUANTITY OF DANGEROUS GOODS						
Dangerous Goods Identification						
UN or ID No.	Proper Shipping Name	Class or Division (Subsidiary Hazard)	Packing Group	Quantity and type of packaging	Packing Inst.	Authorization
UN2842	NITROETHANE	3	III	4 ALUMINIUM DRUMS X 50L OVERPACK USED X 2 #1 #2 TOTAL QUANTITY PER OVERPACK X 200L	355	
UN1325	FLAMMABLE SOLID, ORGANIC, N.O.S., (CACOBITSIN)	4.1	II	1 STEEL DRUM X 60 KG	449	A803
Additional Handling Information						
I hereby declare that the contents of this consignment are fully and accurately described above by the proper shipping name, and are classified, packaged, marked and labelled/placarded, and are in all respects in proper condition for transport according to applicable International and National Governmental Regulations. I declare that all of the applicable air transport requirements have been met.				Name of Signatory SERGEJS GOREVALOVŠ Date 13.07.2022 Signature (see warning above)		

## Patērētāju brīdinājuma zīmes

- **Globally Harmonized System of Classification and Labelling of Chemicals**



Ja uz iepakojuma/preces redzams kāds no šiem marķējumiem un nav citu bīstamības zīmju un deklarācijas, iespējams, ka krava tomēr nav bīstamā un drīkst transportēt neierobežoti.

**Jāprecizē  
Datu drošības lapā**

Patērētāju bīstamības zīmes mūs brīdina par šo produktu bīstamību sadzīvē, bet, vai tie ir bīstami arī transportēšanai, jāpārlicinās ražotāja dokumentos (*Data Safety Sheet*)



Kāda būtiskākā atšķirība starp šiem produktiem (krāsas)?



**Bīstama transportēšanai:  
uzliesmojošs šķidrums**



**Nav bīstama transportēšanai:  
uz ūdens bāzes**



**Gadījumos, kad produkts tikai pēc nosaukuma var būt gan bīstams, gan nebīstams, loģistikas speciālista pienākums ir informēt pārvadātāju par kravas patieso raksturu un sagatavot nepieciešamos dokumentus**

# Dubulta rakstura preces, kas var saturēt kaut ko bīstamu

- Parfimērija
- Farmācijas produkti
- Transp.līdzekļu rezerves daļas
- Rotaļlietas
- Elektronika
- Darba instrumenti
- Reklāmas materiāli
- Sporta aprīkojums
- Saldēti produkti
- Zobārstniecības aprīkojums
- Krāsas, līmes

# Dubulta rakstura preces, kas var saturēt kaut ko bīstamu (2)

Ja prece tiešām bīstama, sūtījums un dokumenti jānoformē saskaņā ar DGR;

Ja konkrētā prece nav bīstama, bet pēc nosaukuma to nevar secināt, uz AWB pie preces nosaukuma obligāti jāpieraksta «**NOT RESTRICTED**»,  
Piemēram: ***pharmaceuticals, not restricted***

# Secinājumi

Bīstamo kravu pārvadājumi – strikti regulēta joma

Visām iesaistītajām pusēm jābūt apmācītām saskaņā ar darba funkcijām

Atbildīgais par sūtījumu sagatavošanu – nosūtītājs

Kravu terminālim obligāta bīstamo kravu akceptēšanas procedūra

**Paldies par uzmanību!**

**Inga Brasla**

**Tel.29 143 884**

**training@be-smart.lv**

